

isodach integral® Technical Data

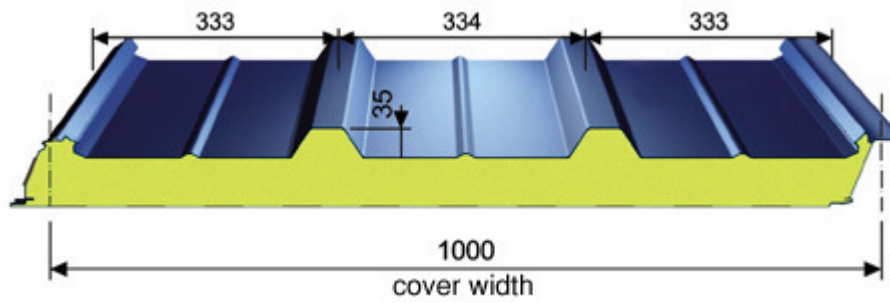

Longitudinal joint

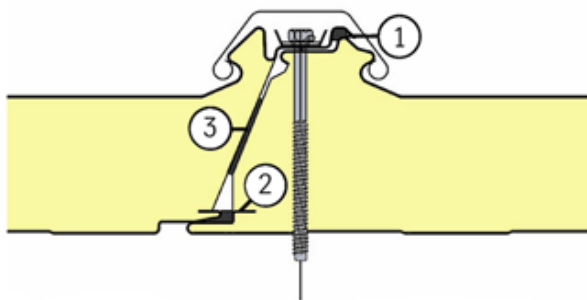

1. External sealing against penetration by surface water
2. Internal sealing for completion of the vapour barrier
3. Sealing strip applied to the foam layer during production to compensate for tolerances

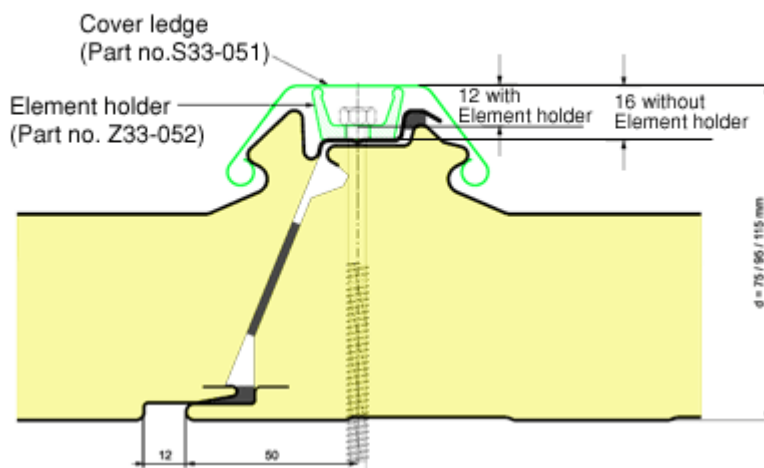

Designation of building element	Element thickness d	Material thickness		max. length supplied	weight	Thermal resistance R*	Heat transfer coefficient U*	Thermal resistance R _D **	Heat transfer coefficient U**	
		Outer sheet 'N	Inner sheet 'N							
	mm	mm	mm	m	kg/m ²	m ² K/W	W/m ² K	m ² K/W	W/m ² K	
Hoesch isodach integral®	75	0,50	0,40	24,0	9,9	1,89	0,49	1,85	0,56	
					13,1					
	95					10,7	2,78	0,34	2,75	0,38
						13,9				
115	0,75	0,50		11,5	3,66	0,26	3,65	0,29		
				14,7						
	135				12,2	4,54	0,21	4,50	0,23	
					15,4					

* calculating acc. to EN ISO 6946

** calculating acc. to EN 13165 taking account of the joints acc. to EN 14 509

Fire resistance

Behaviour in fire as per EN 13501-1, class C-s3,d0

Sound insulation

Sound reduction index = 25 dB.

Air permeability of jointsThe coefficient of air permeability of joints is a = 0.002 m³/h·m·daPa^{1,0}**Material**

Cover sheets: steel according to approval
 Material thicknesses:
 outer shell: see table above
 inner shell: 0,55 mm
 Alternative material for the cover sheets on request.

Insulation core: water-foamed polyurethane (PUR) rigid foam

Cover sheets**Element side**

T = trapezoidally profiled	outside
L = slightly profiled	inside

Approval

General approval no. Z-10.4-345 issued by the Building Authorities

Ref.no. for ordering

Example: isodach integral® TL75i-n / 0.75

isodach integral®	T	L	75	i-n	/	0,75
	Outer shell type	Inner shell type	Element thickness	Type		Material thickness outer shell
	T = trapezoidally profiled	L = slightly profiled	75 mm	integral, 3-ribs		0,75 mm

ThyssenKrupp Bausysteme GmbH

Hammerstraße 11

57223 Kreuztal, Germany

Phone ++ 49 / 2732 / 599 - 1221

Fax ++ 49 / 2732 / 599 - 1219

e-mail export.tks-bau@thyssenkrupp.com

Internet www.tks-bau.com