

Hoesch Additive Floor®

Technical information

The easily mounted floor system
for large spans

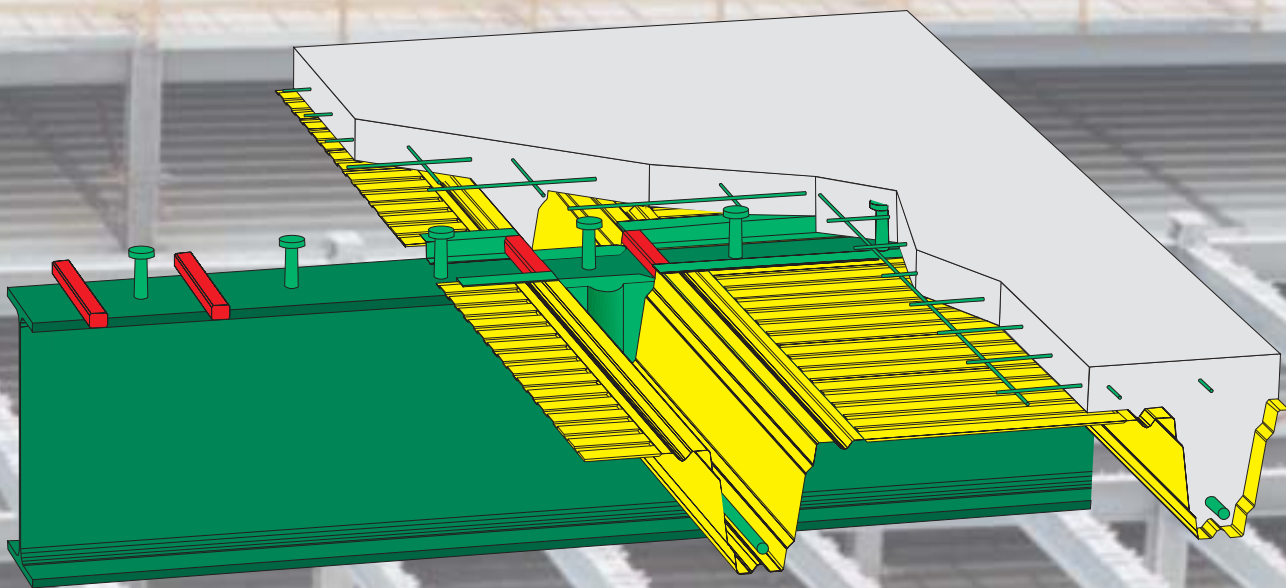

**Floor system
technically approved
Z-26.1-44**



Hoesch Additive Floor®: The easily mounted

Hoesch Additive Floor® ideally combines the benefits of the traditional construction methods known from steel and reinforced concrete structures.

Planners of structural systems increasingly give preference to fabrica-

ted trapezoidal profiles as floor elements. These high profiles allow rapid mounting of the complete structure by applying methods commonly used for steel constructions, without need of auxiliary props during the concrete placing phase which often impede the work. These

floor systems with their large spans offer cost-effective solutions.

The fire resistance of Hoesch Additive Floor® with additional reinforcement corresponds to class F90.



Parking deck in steel composite construction.

floor system for large spans

Benefits of Hoesch Additive Floor®:

- Free spans up to 5.80 m in the concrete placing phase
- Rapid mounting
- Low weight
- No auxiliary props required during construction
- Fire resistance class F90 with additional reinforcement
- Coil-coated with colour finish, suitable as floor with exposed lower side
- Provable economical efficiency

Hoesch services:

- Advice concerning framework design, structural analysis, laying scheme
- Supply of profiled sheets and system flashings



Example: car park in steel composite construction

Principle of Hoesch Additive Floor®:

The firm bearing base.

The characteristic shape of the floor geometry is formed by the Hoesch trapezoidal profile TRP 200. As a result of its high section, the profile has a very good resistance to deflection and a very high flexural strength. The special contour of the trapezoidal profile, which is obtained by applying a patented profiling method, gives the reinforced concrete core a slightly aspect.

In the concrete placing phase, spans of approx. 5.50 m are possible without using auxiliary props.

The trapezoidal profiles stabilise the girders against lateral-torsional buckling and contribute to the overall stability of the structure.

Hoesch trapezoidal profiles TRP are supplied with high-grade ThyssenKrupp Hoesch coating systems and thus meet the requirements of the corrosion protection class III to DIN 55928-8.

The special geometry.

The reinforced concrete core corresponds to a reinforced-concrete ribbed slab to DIN 1045 or to Eurocode part 2. As compared with solid reinforced concrete floors, such floors do have the same resistance to deflection but a substantially lower concrete weight.

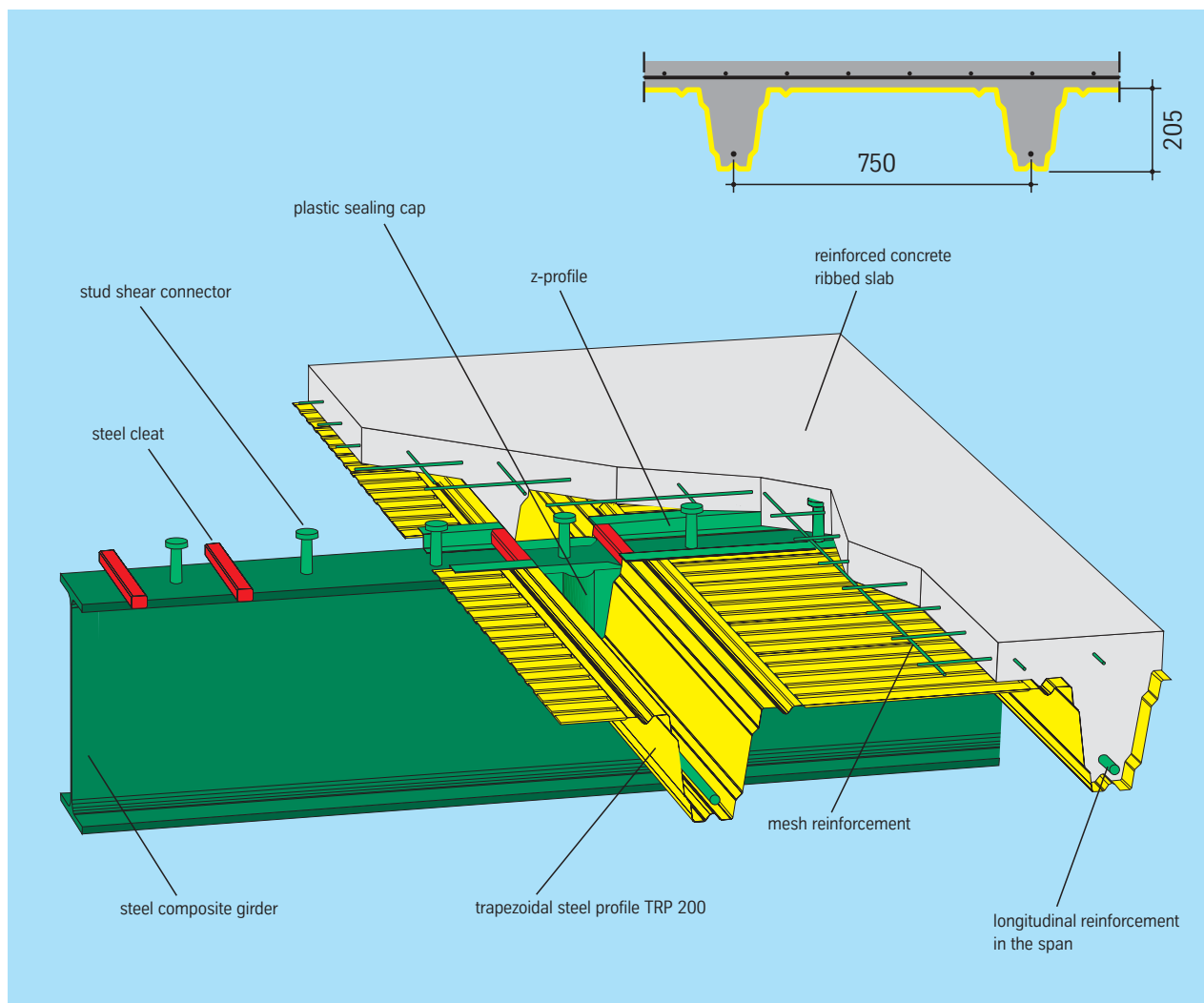

The patented method of support.

The high webs ensure an excellent structural strength and allow to reduce the amount of wire mesh reinforcement.

Hoesch Additive Floor® can be designed for life loads up to approx. 5.0 kN/m² without need of stirrup reinforcement.

Floor and composite girders are connected by means of a patented special method. Hoesch Additive Floor® is laid on solid steel cleats that are welded on the upper chords of the composite girders. In the concrete placing phase, the transverse loads can be transmitted through these steel cleats.

By using stud shear connectors, it is possible to connect floor plate and composite girder, despite the height of the trapezoidal profiles.

There is no reduction of the stud shear connectors' load-bearing capacity due to transversal hollow cells of trapezoidal profiles. Since the upper chords of the steel girders are not covered by crosswise laid trapezoidal profiles, the stud shear connectors can be easily arranged. The ribbed webs of the floor cross section are positioned between the floor joists, which results in a low overall height of the system. Welding the steel cleats in a diagonal manner allows any floor geometry.



Positioning of trapezoidal profiles by using steel cleats.



Easy diagonal positioning of Hoesch Additive Floor®.

Hoesch Additive Floor® in practical appli

Hoesch Additive Floor® is especially suitable for use as floor decking system in multi-storey buildings and car parks. Apart from the short mounting time which is typical for steel structures, Hoesch Additive Floor® offers the additional benefit of a lower overall height, as compared with solid concrete floors.

It should be noted that Hoesch Additive Floor® does not need auxiliary props during concrete placing, which is especially important for the construction of car parks, since it contributes to a favourable crack behaviour.

For special applications, Hoesch Additive Floor® can be used as flat slab version, i.e. with the composite girders being flush with the floor.

Apart from the short mounting time, this floor version offers the benefit of a considerable weight reduction, as compared with reinforced flat slab floors without joists. The amount of concrete can be reduced to approx. 60 % of the quantity needed for a comparable reinforced concrete construction.

The values achieved in terms of foot-step sound and airborne noise depend on the overall floor structure. When applying floating floor screed and a suspended floor, it is possible to have a sound insulation index of $R'_w = 55$ dB.

The spaces between the longitudinal ribs can be used for accommodating leads and conduits.



Car park in service



Parking deck in steel composite construction, mounting phase.

cation



The special benefits of Hoesch Additive Floor® as structural system in detail:

- Free spans up to 5.50 m in the concrete placing phase.
- Lightweight floor structures weighing about 40 % less than solid concrete floors.
- The trapezoidal profile TRP 200 with its high resistance to deflection contributes in all phases to load transmission (additive design). The amount of wire meshing can be reduced.
- The additive system allows for life load up to 5.0 kN/m² without stirrup reinforcement and with a single wire meshing in the supporting area.
- Fire resistance class F 90 possible with additional reinforcement.
- Thanks to the special supporting technique, it is possible to use the high trapezoidal profile TRP 200 in combination with the composite construction (stud shear connectors). Thus, the conventional method is even optimized.
- In the phase of construction, the trapezoidal profiles stabilize the steel joist against lateral-torsional buckling. Temporary horizontal bracings are not required.
- Easy and rapid manual mounting without need of a crane.
- Auxiliary props in the concrete placing phase are not required. Thus, no redistribution of moments due to column settlement and no creep deformation due to dead load. This method, which has a very favourable effect on the concrete's resistance to crack formation, has stood the test especially in the car park construction.
- Other than composite floor profiles, trapezoidal profiles TRP 200 are available with a high-quality coil-coating of the Hoesch coating programme. TRP 200 meets the requirements of the corrosion protection class III to DIN 55928-8.
- The special profile geometry and the coloured finish make Hoesch Additive Floor® particularly suitable as floor with exposed lower side.

The design concept

The design concept during concrete pouring

During concrete pouring the profiles function as form-work and bear all loads. They must not be supported. The steel sheets are formed as structural shear field and can stiffen the structure during the state of construction (structural analysis necessary).

Design loads

The dead loads of the profiled sheets interdependent on the thickness of the steel sheets can be taken from the table on the right.

Cross-section values and characteristic value of bending moment

Nominal sheet thickness	dead load	moment of inertia	moment of span
t_N [mm]	g [kN/m ²]	I_{ef} [cm ⁴ /m]	$M_{F,k}$ [kNm/m]
1,00	0,128	653	17,0
1,25	0,160	855	22,1
1,50	0,192	1030	26,5

The weight of the fresh concrete is calculated in dependency of the thickness of the concrete on top of the sheet h_c according to the following formula:

$$g = 0.87 + 0.26 \cdot h_c$$

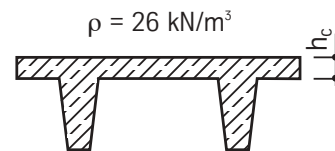

The equivalent load from working process according to DIN 4421 must be calculated for an area of 3 m x 3 m bearing 1.5 kN/m² and for the remaining area with 0.75 kN/m².

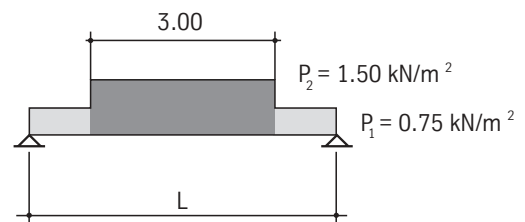

The calculated support width of the profiled sheets is determined by the distance of the fasteners at the supports.

$$L = L_{\text{axial span}} - b_0 - L_K$$

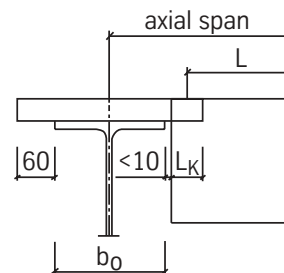

For evidence of the load-bearing security the National technical approval of the floor system (Z-26.1-44) and the profiled sheets (Z-14.1-137) will be applied.

The design during concrete pouring

Support width in state of construction

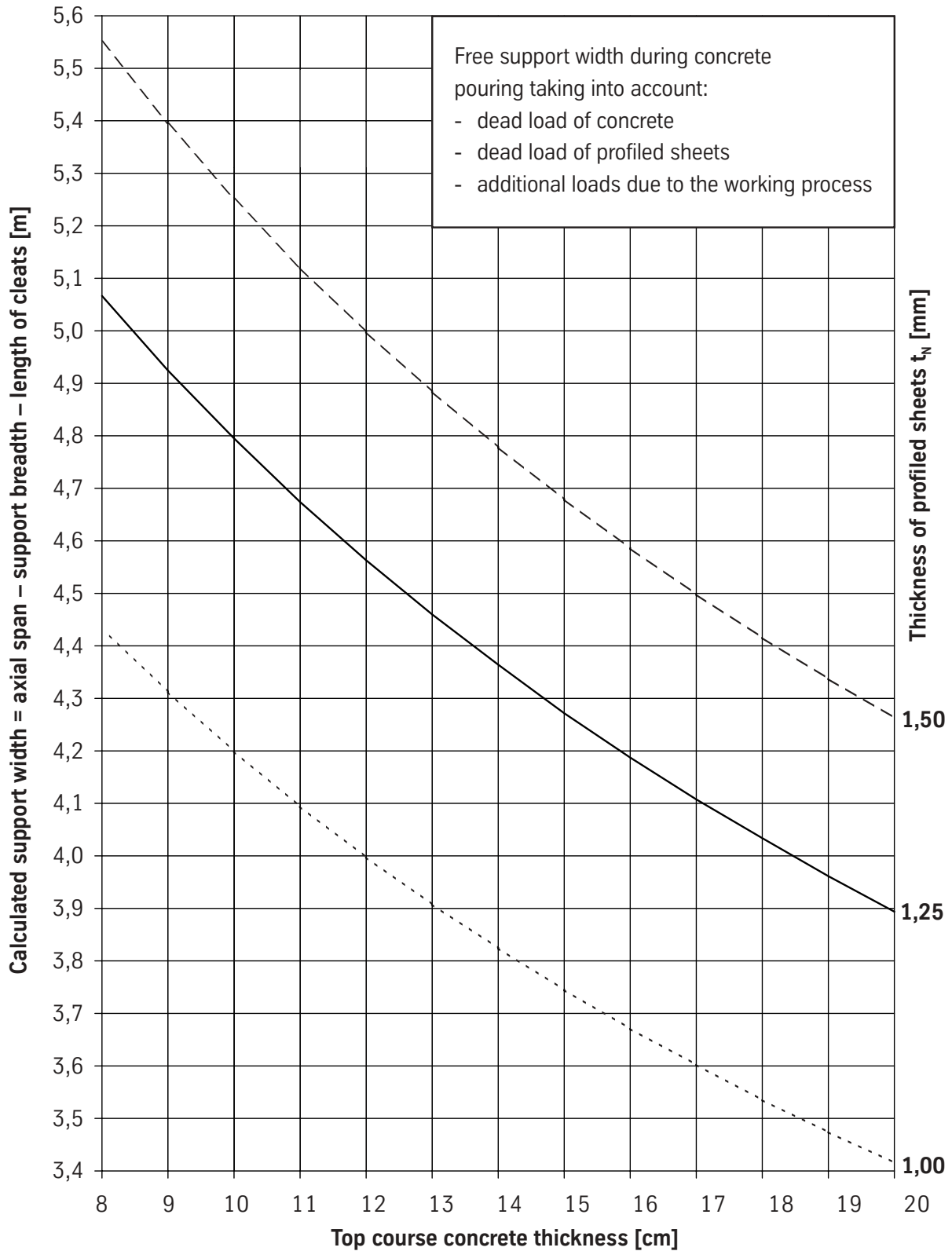

The Design Concept

The design for Service Limit State (SLS)

This design concept has been proved by load-bearing experiments and has proved to be a very good solution for more than 10 years. In January 2003 it was generally approved by DIBt (Deutsches Institut für Bautechnik).

Cold design

The moment of design is carried by both parts (the profiled sheet and reinforced concrete ribbed slab). Their load bearing capacities can be added. Here the load bearing capacity of the profiled sheet is fully made use of and only the difference moment is assigned to the reinforced concrete ribbed slab. In the areas close to the supports the profiled sheet bears all loads. Consequently the bearing of shear force is effected at the supports via the profiled sheet and the patented cleat support. At the delivery point the reinforced concrete ribbed slab has to be proved of its proportional shear force without shearing reinforcement. It can be used as chord of a composite girder and for stiffening the construction.

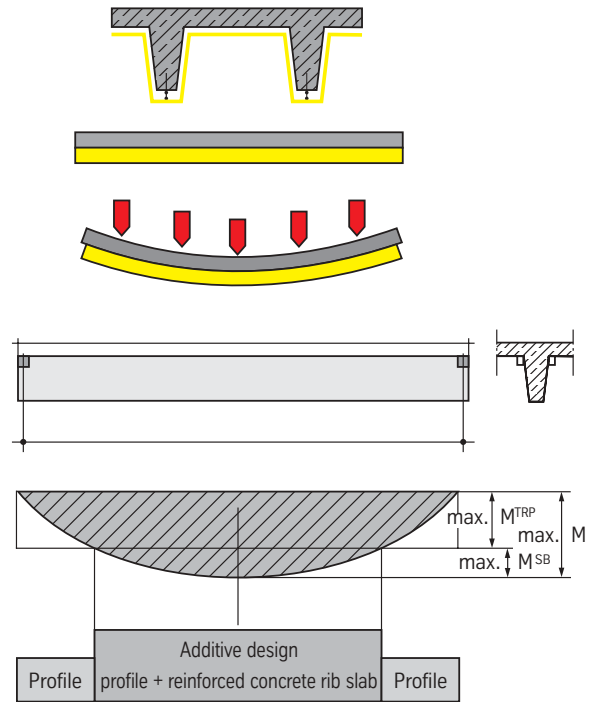

Warm design

After the design for the case of fire the floor construction can be classified according to the fire resistance classes F 30 to F 90. As a result of heating in the case of fire the steel sheet fails and the concrete ribbed slab has to be reinforced accordingly. Suspension reinforcement will be necessary at the supports. The reinforcement bar has to be increased. The shielding effect of the steel sheet while warming the rib can be taken into account.

Design loads

The concrete weight (normal concrete) for the Service Limit State (SLS) is calculated according to the following formula:

$$g = 0.83 + 0.25 \cdot h_c$$

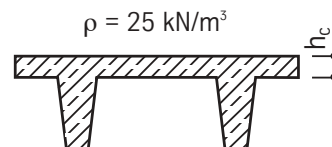

The Design Example

The design of a floor in composite construction

Girder grid	5.00 m x 16.00 m
Composite steel girder	IPE 550
Structural system	single span girder
Basic floor thickness	d = 8 cm
Building materials	
Normal weight concrete	C 35/ 45
Reinforced concrete	BSt 500 S, BSt 500m
Trapezoidal profile	TRP 200, t _n = 1.25 mm

Ultimate limit state (ULS)

Calculated width of supports

L_K = load-bearing edge length of cleats = 50 mm
 b₀ = width of upper chord of steel girder = 210 mm

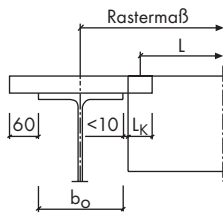

$$L = 5.00 - 0.21 - 0.05 = 4.74 \text{ m}$$

Design loads

$$g_1 = \text{dead load of concrete} = 0.83 + 0.25 \cdot 8 = 2.83 \text{ kN/m}^2$$

$$g_2 = \text{dead load of trapezoidal profile} = 0.16 \text{ kN/m}^2$$

$$\Sigma g = 2.99 \text{ kN/m}^2$$

$$p = \text{live load according DIN 1055} = 3.50 \text{ kN/m}^2$$

Internal forces

$$M_{Ed,max} = (g \cdot \gamma_G + p \cdot \gamma_Q) \cdot L^2 / 8$$

$$M_{Ed,max} = (2.99 \cdot 1.35 + 3.50 \cdot 1.5) \cdot 4.74^2 / 8$$

$$M_{Ed,max} = 26.08 \text{ kNm/m}$$

Bending design of reinforced concrete ribbed slab

$$M_{Ed,max} / M_{Rd} \leq 1$$

$$M_{Rd} = M_{PT,Rd} + M_{c,Rd} = M_{Ed,max}$$

$$\text{with } M_{PT,Rd} = M_{PT,Rk} / \gamma_M = 22.1 / 1.1 = 20.09 \text{ kNm/m}$$

$$\text{reg. } M_{c,Rd} = M_{Ed,max} - M_{PT,Rd} = 26.08 - 20.09 = 5.99 \text{ kNm/m}$$

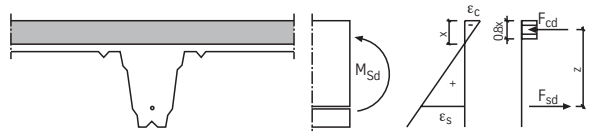

Strain hypothesis:

$$\epsilon_c / \epsilon_s = - 0.17 / 25 \text{ in } \text{‰}$$

$$\rightarrow x = d \cdot |\epsilon_c| / (|\epsilon_c| + \epsilon_s)$$

$$\text{with } d = h_{TRP} + h_c - u = 20.5 + 8.0 - 4.5 = 24 \text{ cm}$$

$$x = 24 \cdot 0.17 / (0.17 + 25) = 0.16 \text{ cm}$$

Concrete pressure:

$$F_{cd} = A_{cc,red} \cdot f_{cd}$$

$$\text{with } A_{cc,red} = b \cdot 0.8x = 100 \cdot 0.8 \cdot 0.16 = 12.8 \text{ cm}^2$$

$$f_{cd} = 0.85 \cdot 3.5 / 1.5 = 1.98 \text{ kN/cm}^2$$

$$F_{cd} = 12.8 \cdot 1.98 = 25.34 \text{ kN}$$

Lever:

$$z = d - a = 24 - 0.8x / 2 \approx 24 \text{ cm}$$

Equilibrium:

$$M_{Ed} = F_{cd} \cdot z$$

$$5.99 = 25.34 \cdot 0.24 = 6.08 \text{ kNm/m}$$

→ Strain hypothesis correct!

Steel tension:

$$F_{sd} = F_{cd} = 25.34 \text{ kN}$$

Reinforcement:

$$\epsilon_s = 25 \text{ ‰} \rightarrow \sigma_s = f_{yd} = 50.0 / 1.15 = 43.5 \text{ kN/cm}^2$$

$$\text{reg. } A_s = F_{sd} / f_{yd} = 25.34 / 43.5 = 0.58 \text{ cm}^2/\text{m}$$

$$\text{reg. } A_{s,rib} = 0.75 \cdot 0.58 = 0.44 \text{ cm}^2/\text{m}$$

$$\text{Chosen: } 1 \text{ } \emptyset 8 \text{ mm, } \text{prov. } A_s = 0.503 \text{ cm}^2$$

Calculation of shear force of reinforced concrete ribbed slab

$$V_{c,Ed,max} / V_{c,Rd} \leq 1$$

$$V_{c,Ed,max} = q_{c,Ed} \cdot L_c / 2$$

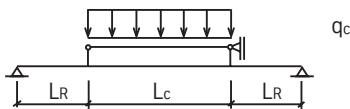
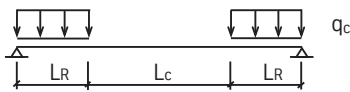
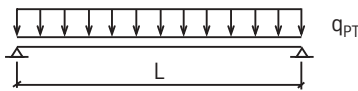

with $q_{c,Ed} = p_d + g_{c,d} + g_{AB,d}$
 $= 3.5 \cdot 1.5 + 2.83 \cdot 1.35 + 0 = 9.07 \text{ kN/m}^2$
 $M_{c,Ed} = q_{c,Ed} \cdot L_c^2 / 8$
 $L_c = \sqrt{(8 \cdot M_{c,Ed} / q_{c,Ed})} = \sqrt{(8 \cdot 5.99 / 9.07)} = 2.30 \text{ m}$

$$V_{c,Ed,max} = 9.07 \cdot 2.30 / 2 = 10.42 \text{ kN/m}$$

$$= 10.42 \cdot 0.75 = 7.82 \text{ kN / rib}$$

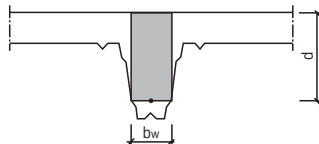

$$V_{c,Rd} = 0.1 \cdot \kappa \cdot (100 \cdot \rho_l \cdot f_{ck})^{1/3} \cdot b_w \cdot d$$

with $\rho_l = A_{sl} / b_w \cdot d$
 with $A_{sl} = 0.503 \cdot 10^2 = 50.3 \text{ mm}^2$
 $d = 240 \text{ mm}$
 $b_w = 100 \text{ mm}$
 $\rho_l = 50.3 / 240 / 100 = 2.1 \text{ ‰}$
 $\kappa = 1 + \sqrt{(200 / d)} = 1 + \sqrt{(200 / 240)} = 1.913$
 $f_{ck} = 35 \text{ N/mm}^2$
 $V_{c,Rd} = 0.1 \cdot 1.913 \cdot (100 \cdot 0.0021 \cdot 35)^{1/3} \cdot 100 \cdot 240$
 $= 8927 \text{ N / rib}$
 $V_{c,Rd} = 8.93 \text{ kN / rib} > V_{c,Ed,max} = 7.82 \text{ kN / rib}$

Calculation of anchor of rib-reinforcement

$$L_R \geq l_{b,net} + d$$

with $l_{b,net} = \alpha_a \cdot l_b \cdot A_{s,erf} / A_{s,vorh} = l_{b,min}$
 with $\alpha_a = 1.0$
 $l_b = f_{yd} / f_{bd} \cdot d_s / 4$
 with $f_{yd} = 500 / 1.15 = 435 \text{ N/mm}^2$
 $f_{bd} = 3.4 \text{ N/mm}^2$
 $d_s = 8 \text{ mm}$
 $l_b = 435 / 3.4 \cdot 8 / 4 = 256 \text{ mm}$
 $A_{s,erf} = 0.432 \text{ cm}^2$

$$l_{b,min} = \max(0.3 \cdot l_b; 10 \cdot d_s; 100) = 100 \text{ mm}$$

$$L = L_c + 2 \cdot L_R$$

$$L_R = (L - L_c) / 2 = (4.74 - 2.30) / 2 = 1.22 \text{ m}$$

$$1.22\text{m} > 0.22 + 0.24 = 0.46 \text{ m}$$

The slab reinforcement is laid according to the reinforced concrete guidelines.

Calculating the composite girders can be effected in correspondence with the guidelines for composite constructions. Reducing the load-bearing capacity of the stud shear connector as a result of the hollow cells of the trapezoidal profile running crosswise is not necessary.

The calculation for the Service Limit State (SLS) is not subject of this example. A detailed calculation example can be downloaded from our web site.

Details for construction

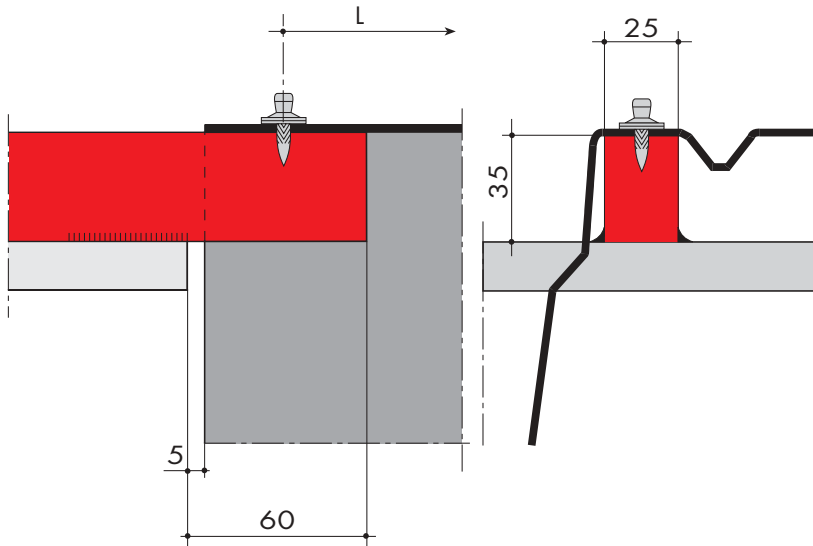

Placing on steel cleats

As a rule the steel cleats are fixed by a fillet weld to the upper chord before galvanising or coating the steel girder. To fasten the profiles to the supports (generally approved) fire shot fasteners are required. The quality of the material of the cleats should not exceed S 235 in order not to impede the installation of fasteners unnecessarily. Keeping to the given dimensions the system flashings (z-sealing profiles and plastic sealing caps) can be used.

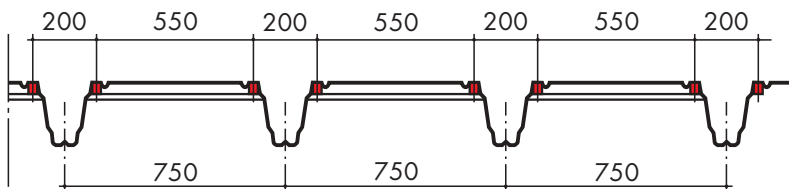

Standard axial dimensions

The standard dimensions for the arrangement of the steel cleats are shown in the picture on the left.

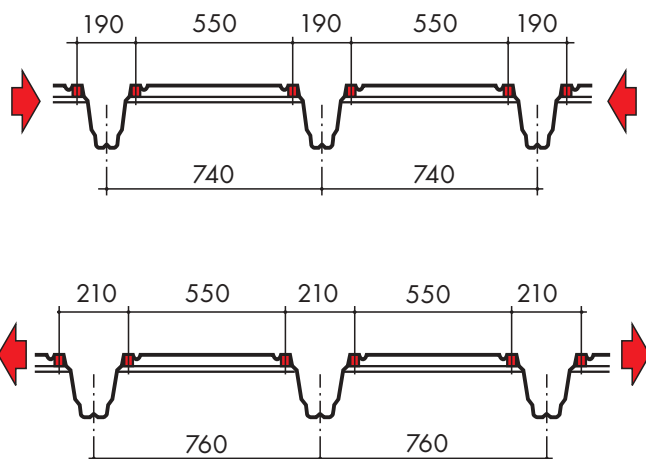

Deviating grid dimensions

Reducing or expanding the grid up to 10 mm is possible without any problems to keep to the prescribed conditions for the edge. The profiled sheets centre themselves during installation.

Examples for performance

Sealing of upper chord

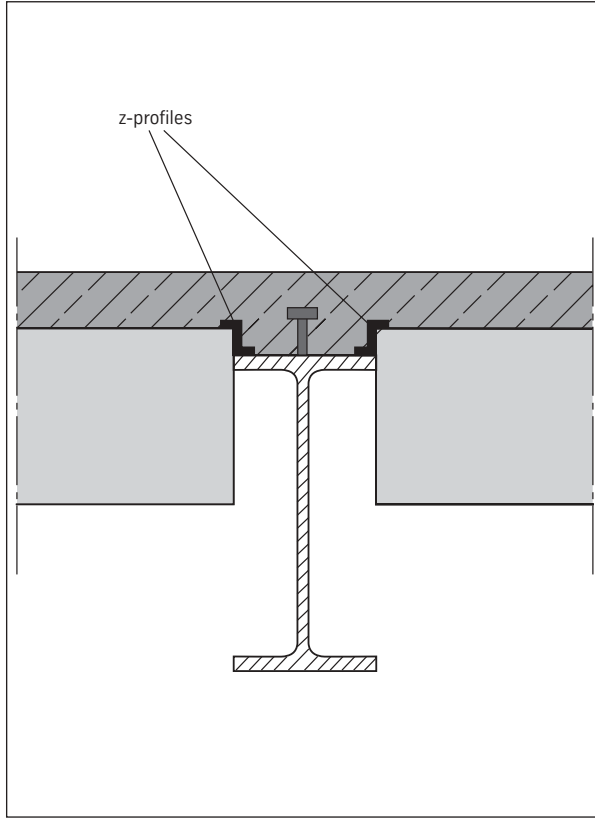

Sealing of rib

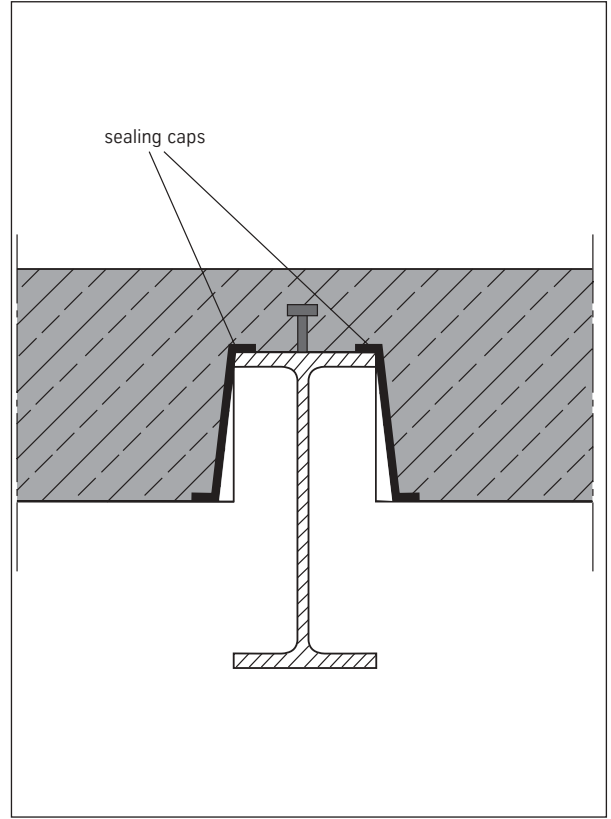

Edge formation

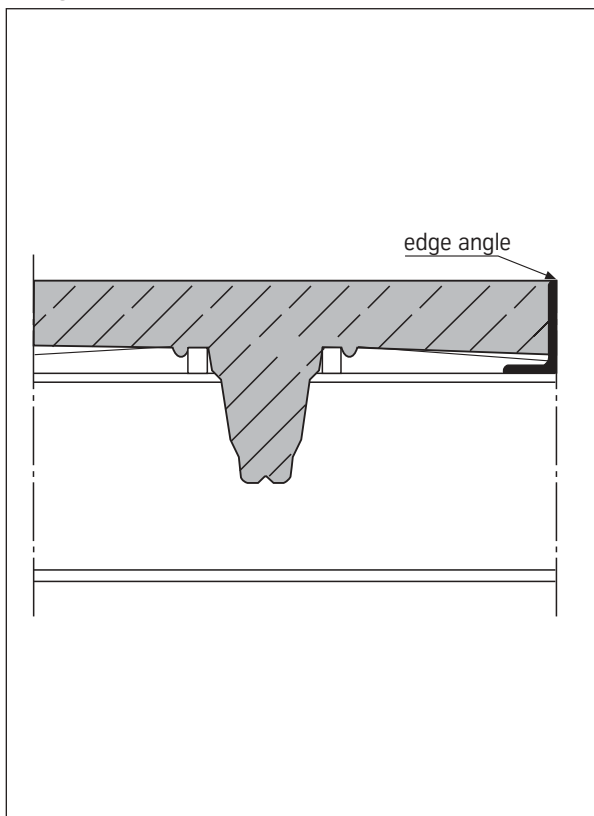

Intermediate supports

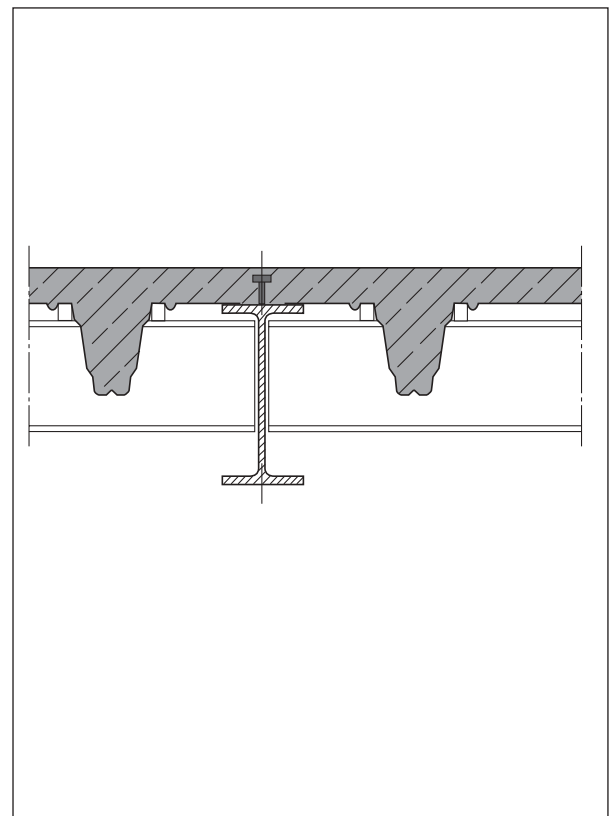

Installation

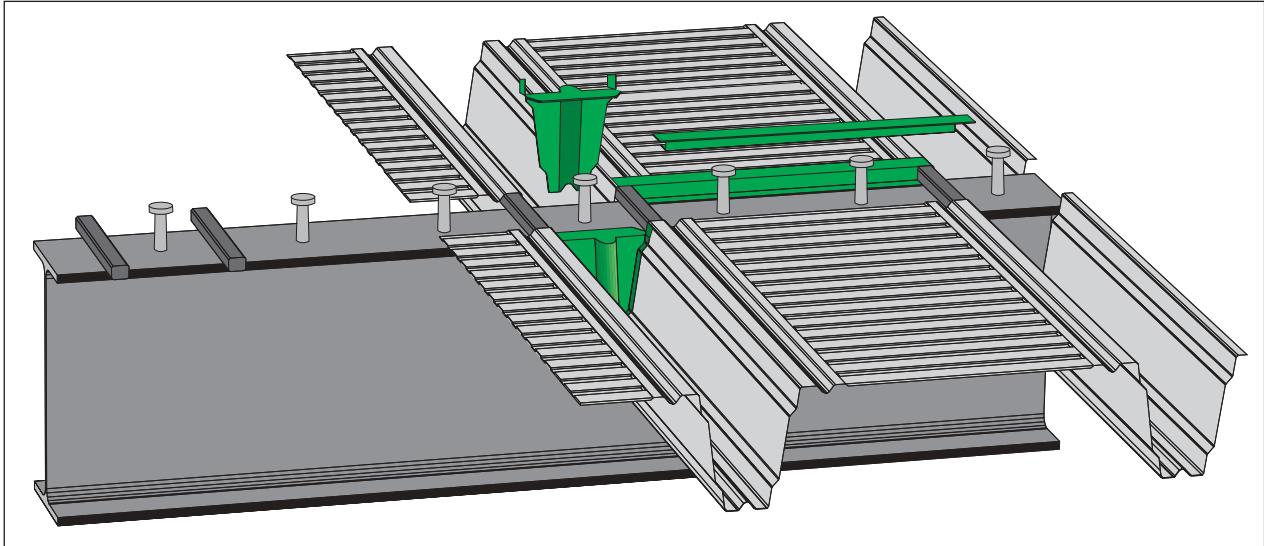

Before installation

- Placing the profile packages on squared timbers near supports. While placing in centre of span packages may fall down!
- Checking the distances between girders in centre of span and, if necessary, safeguarding the distances by suitable measures (towing bars, wedging them tightly, etc.)
- Checking the torsion protection of the edge girders.

Installation

- Installing the profiles by hand in positive position on cleats made of square steel (25 x 35 mm). Profiles for the long side are to be separated at the top chords and placed on the edge folds.
- Balancing of margins at both ends of the profiles.
- Installing the z-sealing profiles.
- Fastening the profiles and z-profiles to the cleats with one fire shot fastener each admitted by the construction supervising authorities (e. g. HILTI ENP 2-21 L15 or any equivalent).
- Installing the polyurethane caps under an angle of about 10° to balance the margins of the profiles. In this process the cap is leaning against the top chords of the girders and is being supported by a screw in the bottom chord.
- Screwing the profiles together by using fasteners admitted by the construction supervising authorities (e. g. drill screw SFS SX 3/10-m- A10-5,5 x 28 or any equivalent) in a distance of 666mm. If the profiles are used as shear fields as planned during the process of concreting, the distances between the screws must be proved structurally. For optical

reasons the screwing process is usual carried out on the underside.

- Fastening the long sides to the edge folds with the same distance like the profile joints.

After concrete pouring

- Longitudinal and cross sections on sheet metal must be done by using shearing-, pressing- or sawing tools. The use of separating grinders („hot cut“) is not allowed (see IFBS- Info 8.01).
- Jointing elements that are mostly exposed to air outdoors have to consist of stainless material (see national technical approval no. Z-14.1-4).
- Before concreting the methods of jointing applied must be accepted and taken down by the engineer in charge. The report of acceptance is part of the building diary! During the process of concreting unscrewed ribs will burst open due to the pressure of fresh concrete.
- After concreting, dirtyings of the trapezoidal profiles must be removed immediately with little water. Using a high-pressure cleaner is recommended.

Comment

When laying the profiled sheets the relevant installation guidelines of the IFBS (IFBS-Info 8.01) must be observed.

As standard flashings the plastic sealing caps as well as the z-profiles to seal the sheets against the upper chord of the girder are included with the delivery. For diagonally cut profiles a PIR block shaped equally can be obtained which can be cut into slices and glued into the profiles. Thus any angle up to 60° is possible.

ThyssenKrupp Hoesch Bausysteme GmbH

Hammerstrasse 11

D-57223 Kreuztal, Germany

Phone ++ 49/27 32/599 - 12 21, Fax ++ 49/27 32/599 - 12 19

e-mail: export@tkb-bau.thyssenkrupp.com

Internet: www.tks-bau.com



All details contained in this brochure are only guaranteed insofar as they have been expressly and specifically confirmed in writing. Subject to technical modifications.
GB, Info 3.1.1 • 10/2005 • bc

