

Hoesch isodach integral®

Technical information



A company
of ThyssenKrupp
Steel

ThyssenKrupp Bausysteme



ThyssenKrupp

Contents

	Page
General	3
Main dimensions and properties.....	4
Corrosion protection	5
Thermal protection / Insulating core	5
Fire protection	5
Information on design	6
Examples of designs	7

1. General

A further development of the Hoesch isodach integral® sandwich panel unites the positive properties of the joint geometry (Triplex) which is well known from thermodach panels and, in most cases, concealed fastening technology which is an ideal supplement to sandwich wall panels produced by ThyssenKrupp Bausysteme. The concealed fastening in the roof surface gives a homogeneous visual effect thereby meeting exacting architectural demands.

The building owner has a modern, functionally safe and high-quality building element. It is not necessary to use special pressing tools for erection. The high standards applied to roof safety are fully complied with.

Hoesch isodach integral®

- Permanently weather tight against rain, wind and snow
- Firmly fastened to be resistant to wind uplift forces
- Almost maintenance-free, keeps its value
- Low project costs as a result of the short installation time
- High load-bearing capacity
- Excellent thermal insulation with a U value of 0,28 W/m²K (roofing panel TL115i)

Quality assurance

In addition to regular in-house production control the conditions of the approval demand external supervision by an independent test institute. Furthermore, the quality criteria of RAL-GZ 617 are complied with.

Joint sealing using the Triplex system:

1. External sealing against penetration by surface water
2. Internal sealing for completion of the vapour barrier
3. Sealing strip applied to the foam layer during production to compensate for tolerances

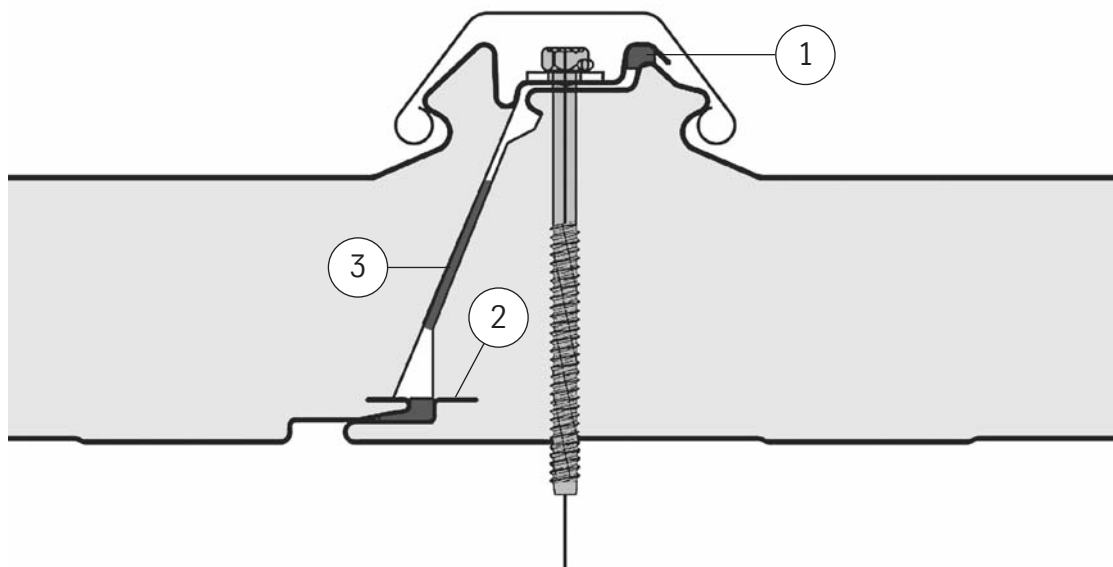

Joint detail, concealed fastening

2. Main dimensions and properties

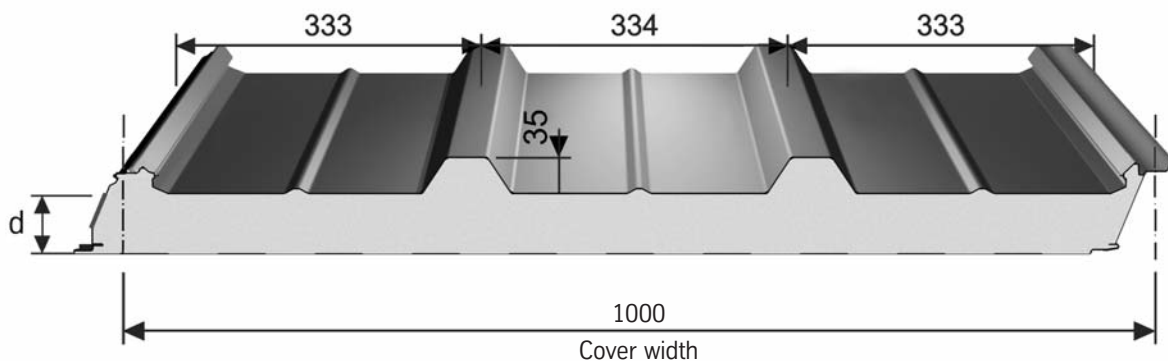

Designation of building element	Element thickness d	Material thickness		Max. length supplied	Weight	Thermal resistance R*	Heat transfer coefficient U*	Thermal resistance R _b **	Heat transfer coefficient U**
		outer sheet t _N	inner sheet t _N						
	mm	mm	mm	m	kg/m ²	m ² K/W	W/m ² K	m ² K/W	W/m ² K
Hoesch isodach integral®	75	0.50 0.75	0.40 0.50	24	9.9 13.1	1.89	0.49	1.85	0.56
	95				10.7 13.9	2.78	0.34	2.75	0.38
	115				11.5 14.7	3.66	0.26	3.65	0.29
	135				12.2 15.4	4.54	0.21	4.50	0.23

* calculation acc. to EN ISO 6946

** calculation acc. to EN 13 165 taking account of the joints acc. to EN 14 509

3. Corrosion protection

3.1 Standard coating systems for Hoesch isodach integral®

Abbreviation	Coating system	Nominal layer thickness (µm)	Class of corrosion DIN 55928-8
PLADUR® PVF ²	PVF ² Polyvinylidene fluoride	25	III
PLADUR® SP	SP Polyester	25	III
PLADUR® DU	DU Polyester	15	II

Other systems are available on request. Special recommendation for roofs when no colour is specified:

GALVALUME® (AZ 185) without coating

This alloy-galvanized cover sheet achieves, without any additional coil coating, corrosion protection class III as per DIN 55928-8. The layer weight is 185 g/m².

Other variations for the faces such as aluminium or stainless steel are available on request.

4. Thermal protection / Insulating core

The insulating core made from closed-cell HFCW-free polyurethane rigid foam with its excellent thermal insulation properties connects the steel faces in a manner so as to be shear-resistant. Its high compressive strength is essential to give the high rigid-

ity and the extraordinary load-bearing capacity of the panels. PUR rigid foam is to a great extent resistant to chemicals that may commonly occur in practice. Its behaviour with respect to other materials is chemically neutral, and it does not contain

any substances which promote corrosion. Its resistance to fungi and microbes guarantees resistance against rotting and putrefaction. This roof system is also available with PIR-foam on request.

5. Fire protection

Hoesch isodach integral® is a combination of non combustible, coil-coated steel cover sheets (building material class A2, according to DIN 4102-1) and normally inflammable insulating material. In accordance with DIN EN 13501-1, building material class C-s3, d0 (virtually non-

inflammable) is achieved. The panels are resistant to flying sparks and radiated heat as per DIN 4102-4. Thus, they meet the criteria for "hard roofing" (premium guideline of the association of property insurers). Furthermore, the sandwich panels comply with the B_{ROOF} classification

as per DIN EN 14 509 on the behaviour in fire in the case of external impact on roof coverings. Sandwich panels with a core consisting of polyurethane rigid foam demonstrably do not contribute to the spread of a fire load.

6. Information on design

6.1 Roof slope

It is recommended that the following roof slopes are observed:

- roofs without end laps and without roof apertures $3^\circ \approx 5\%$
- roofs with end laps and with roof apertures $5^\circ \approx 9\%$

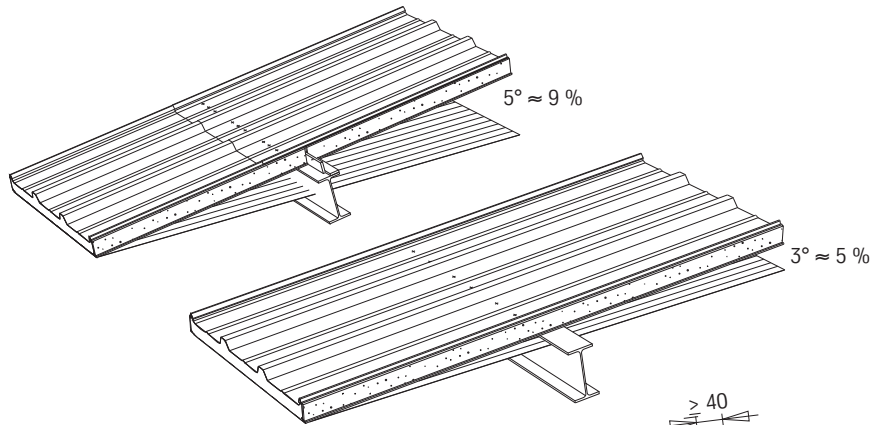

6.2 Width of support

In accordance with the official approval, the following minimum supporting widths must be observed:

- | | |
|------------------------|--------------|
| intermediate supports: | ≥ 60 mm |
| end supports: | ≥ 40 mm |
| end lap: | ≥ 85 mm |

The data given in the structural analysis and in the detailed drawing, respectively, are determining.

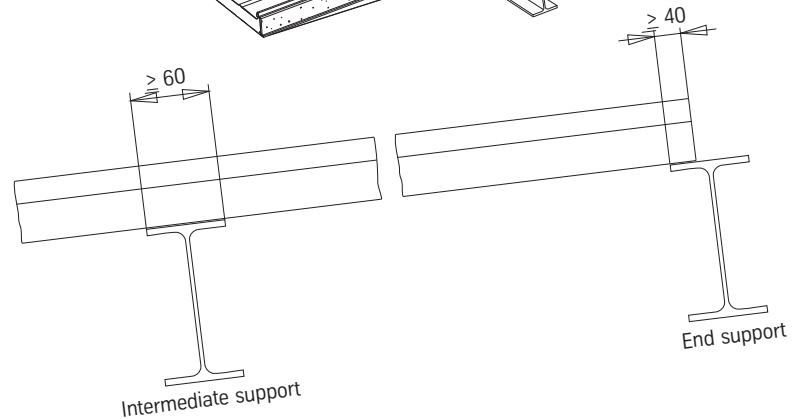

6.3 Fastening

Fastening of Hoesch isodach integral® panels is concealed by the joint cover profile (part.no. S33-051). Normally, only one fastener is required per longitudinal joint at the crossing point with the purlin. Fastening is made using screws and either washers or load distribution plates (part no. Z33-051 and Z33-052, respectively). The appropriate version is specified in the structural analysis and the laying plans. Design tables may be helpful for preliminary calculation. They can be found on the Internet under www.tksbau.com.

For fastening Hoesch isodach integral® panels to the supporting structure, officially approved fasteners with a minimum diameter of 6.3 mm made from stainless steel are required.

Depending on the material and the thickness of the supporting structure, different screw types are required.

Where high demands are imposed on the tightness of the longitudinal joint, or in the case of high deflections and high utilisation of the load-bearing capacity, it is

recommended that screws spaced at 500 or 600 mm are provided in the longitudinal joint also between the supporting points.

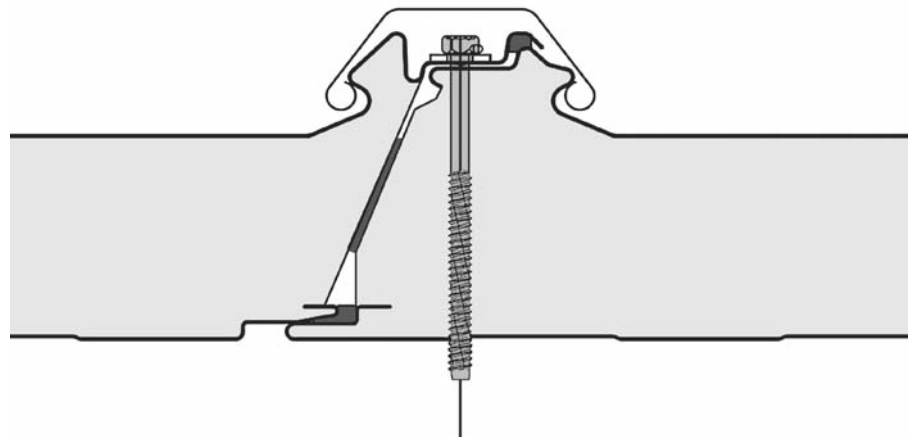

7. Examples of designs

The examples of designs shown hereafter are basic recommendations which are intended to ensure that buildings are free from defects and are erected in a professional and appropriate manner according to the state of the art, provided that they are subject to normal loads. They have been selected on the basis of our own and

our customers' experience. Further examples can be found on the Internet under www.tks-bau.com "Konstruktionsvorschläge". Adopting these examples does not relieve the user from the responsibility for his own action to suit local conditions and circumstances. Furthermore, we refer to the information issued by IfBS, in particular

to bulletin no. 4.02 "Building physics, tightness of joints in light-gauge steel construction", which gives details. Also use the guide to good practice from the National Federation of Roofing Contractors (UK).

7.1 Ridge

Before laying Hoesch isodach integral®-panels, the two ridge purlins should be bridged using an internal ridge flashing, adapted to suit the roof slope. This allows the joint between the panels to be closed using PUR foam or mineral wool and this ensures that the underside is visually faultless.

Surface water is prevented from penetrating into the building by the lower flange of the cover sheet for approx. 30 mm of which is folded up. This is particularly important in the case of roofs with a shallow slope.

The wind barrier is formed by a filler section made from cellular polyethylene which is covered by a serrated plate. It is important to make this connection watertight by using sealing strips as shown and silicon if necessary. A ridge cap is then placed against the upper flanges of the roofing panels on either side of the roof and fastened with screws. The minimum dimensions of screws and washers are as follows:

Screw diameter: 6.3 mm

Washer diameter: 16.0 mm

Screws without a thread immediately below the head are suitable for this purpose.

The panels are fastened as described in 6.3. Additionally, fasteners can be used below the ridge cap in the lower flange of the upper cover sheet. At the longitudinal joints of the panels, in the area of the sealing strip (5) and at the cross joints of the ridge plate (7) additional sealing is required.

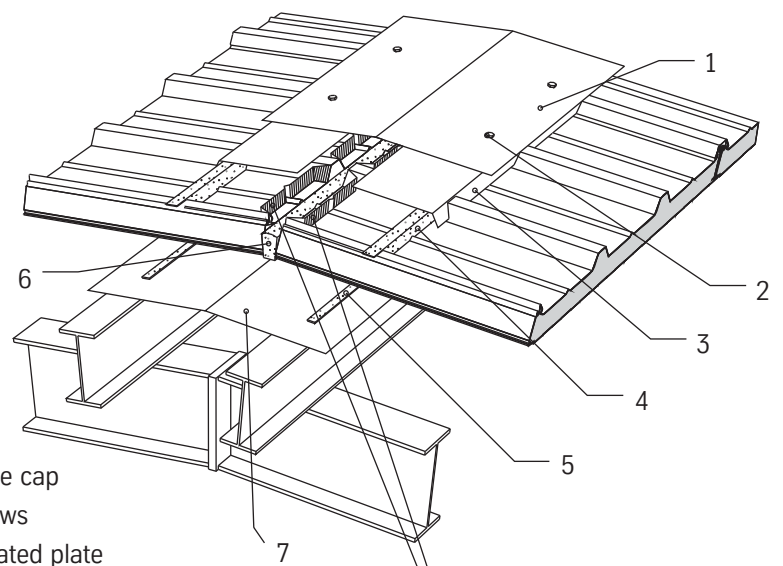

- 1 Ridge cap
- 2 Screws
- 3 Serrated plate
- 4 Profile filler
- 5 PVC sealing strip, closed-cell, 5 x 20 mm
- 6 In-situ PUR foam
- 7 Ridge plate

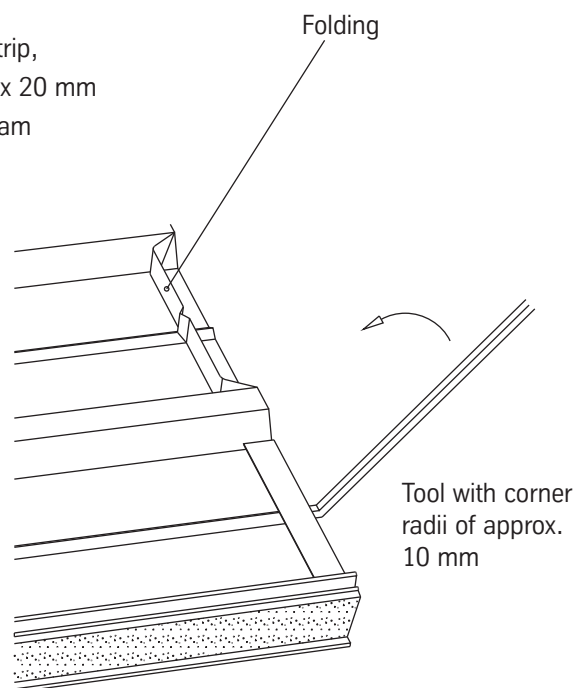

7. Examples of designs

7.2 Eaves

Hoesch isodach integral® panels require continuous support across the complete width. Therefore, when they are fastened to edge supports, the gutter brackets must be mounted flush. If this is not possible, e.g. when fastening directly to steel or concrete structures, the space between the gutter brackets must be filled in. In the eaves area, sealing strips of 5 x 20 mm and 10 x 25 mm, respectively, must be inserted between the Hoesch isodach integral® panels, the supporting structure and the sheet accommodating the gutter in order to compensate for constructional tolerances and for sealing purposes.

Depending on the climatic conditions and their impact on the building, the inside steel sheet of Hoesch isodach integral® may be thermally uncoupled from the outside by a small slit (approx. 3 mm wide). Special attention however should be paid to ensure that the end supporting conditions as per structural analysis are observed.

It is recommended that a water guidance sheet (part no. K30-...) is installed at the eaves edge to ensure that water can run off in an unimpeded manner under the influence of a strong wind and also for concealing the cut surface of the panel.

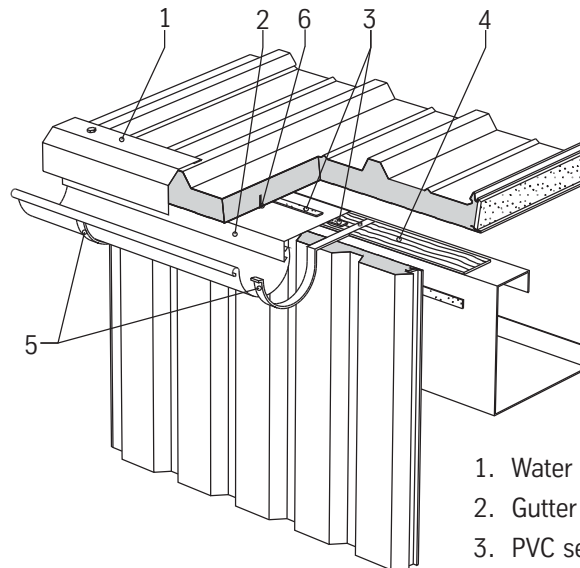

1. Water guidance sheet
2. Gutter inlet sheet
3. PVC sealing strip, closed-cell, 5x20 mm
4. Space between gutter brackets filled in
5. Gutter brackets
6. Possible slit

7.3 Verges

Before the verge profile is installed, the joint between the roofing panels and the wall structure is filled in using PUR foam (as in the ridge area). This reduces the formation of thermal bridges in the thermal insulation. Another improvement may be achieved by thermally uncoupling the small inside from the outside by a slit (approx. 3 mm wide). Special attention however should be paid to ensure that the end supporting conditions as per structural analysis are observed.

The verge profile is fastened to the ribs of Hoesch isodach integral® at a distance of 500 mm using two staggered rows of screws.

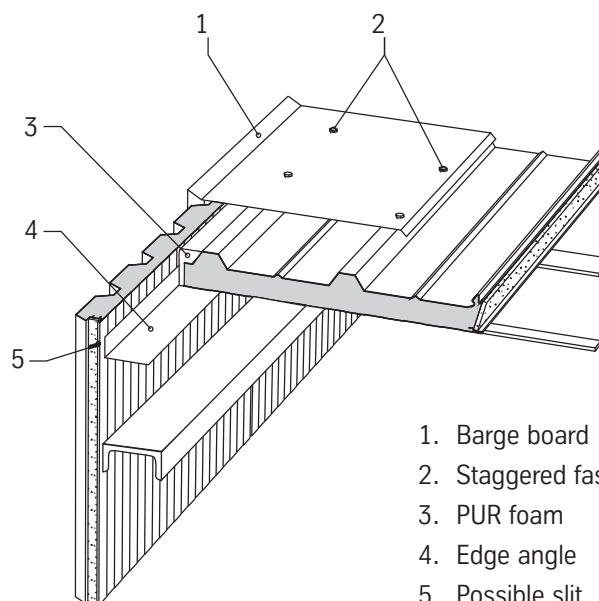

1. Barge board
2. Staggered fastening
3. PUR foam
4. Edge angle
5. Possible slit

7. Examples of designs

7.4 Roof apertures

Any apertures for lighting, ventilation and/or smoke extraction should be carefully planned and executed. Commercially available rooflights, which are continuously arranged in the ridge or at right angles from the ridge to the eaves, have proved to be appropriate. They can be easily installed, and they allow a roof slope of $3^\circ \approx 5\%$.

Connections to the roof area are made in the same way as those described in the "ridge" and "verges" chapters.

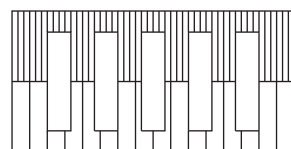
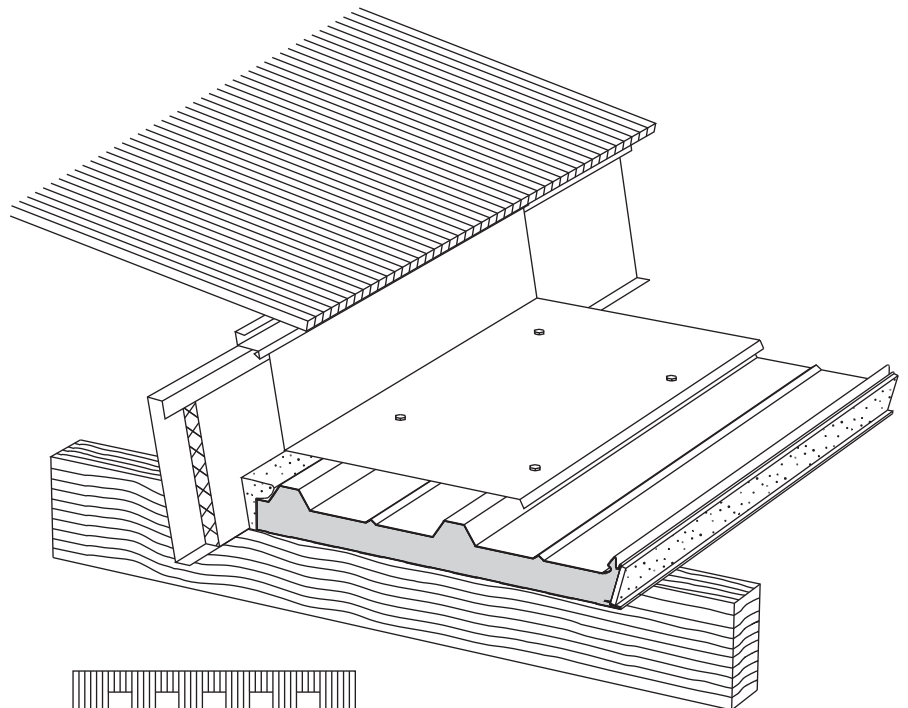
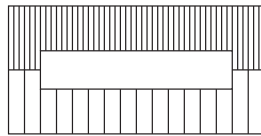
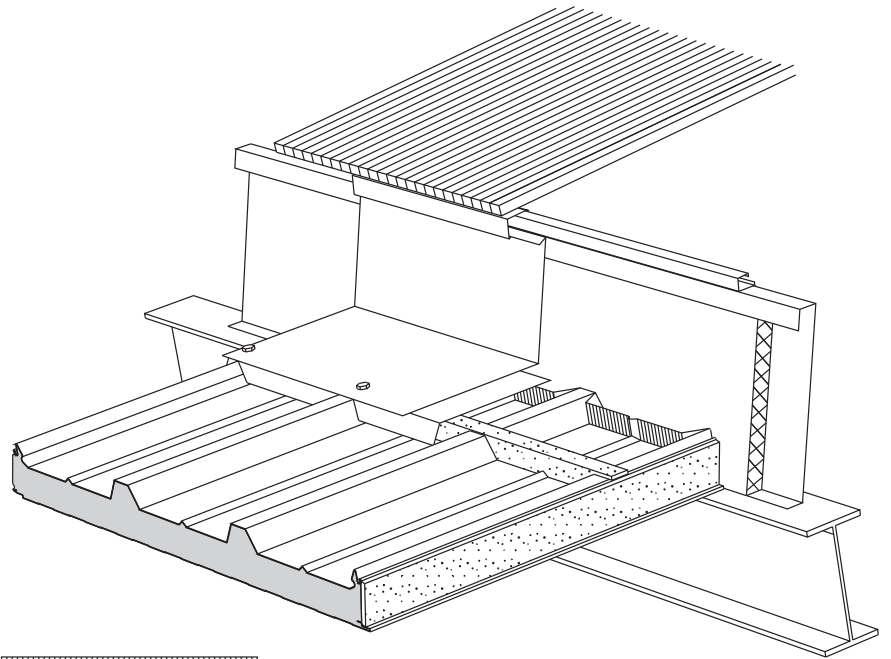

7. Examples of designs

7.5 Subsequent installations

Apertures in the roof, which may become necessary later e.g. as a result of a change in the use of the building, should be cut and sealed as shown.

Transmission of any loads which occur requires a structural analysis, and special construction measures (framings) may be necessary.

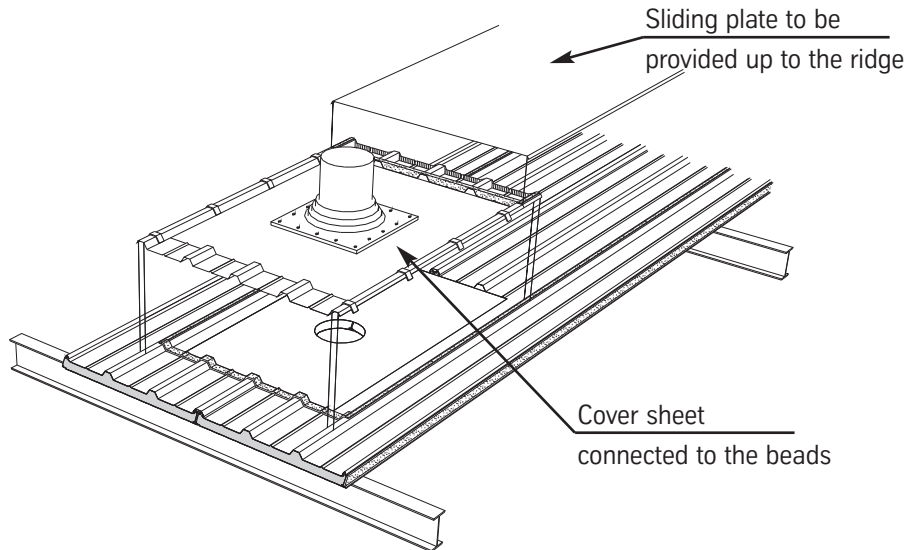

When making apertures, connections to the outside steel face of the Hoesch isodach integral® panels must be made very carefully. The same applies to vapour-tight connection of the inside steel face.

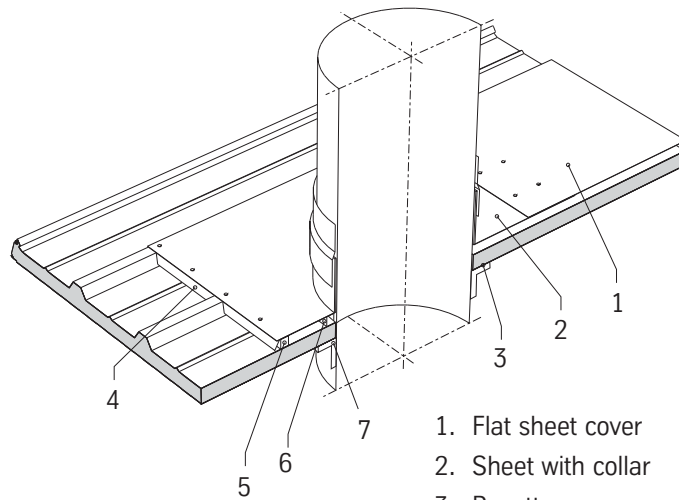

1. Flat sheet cover
2. Sheet with collar
3. Rosette
4. Serrated sheet
5. Profile filler
6. Folding
7. Connect the inside steel face so that it is vapour-tight

Small apertures for pipes (max. Ø 200 mm) can be provided using pipe sleeves which adapt themselves to suit the profile geometry. The system is completed by a stainless steel hose sleeve which seals the pipe sleeve and the pipe.

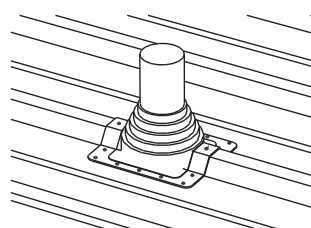

ThyssenKrupp Bausysteme GmbH

Hammerstrasse 11

D-57223 Kreuztal, Germany

Phone: +49 / 27 32 / 599 1 221

Fax: +49 / 27 32 / 599 1 219

E-Mail: export.tks-bau@thyssenkrupp.com

Internet: www.tks-bau.com



All details contained in this brochure are only guaranteed insofar as they have been expressly and specifically confirmed in writing. Subject to technical modifications.
GB • Info 2.6.1 • 12.2007 • DC

