

Hoesch isodach integral®

Installation recommendations

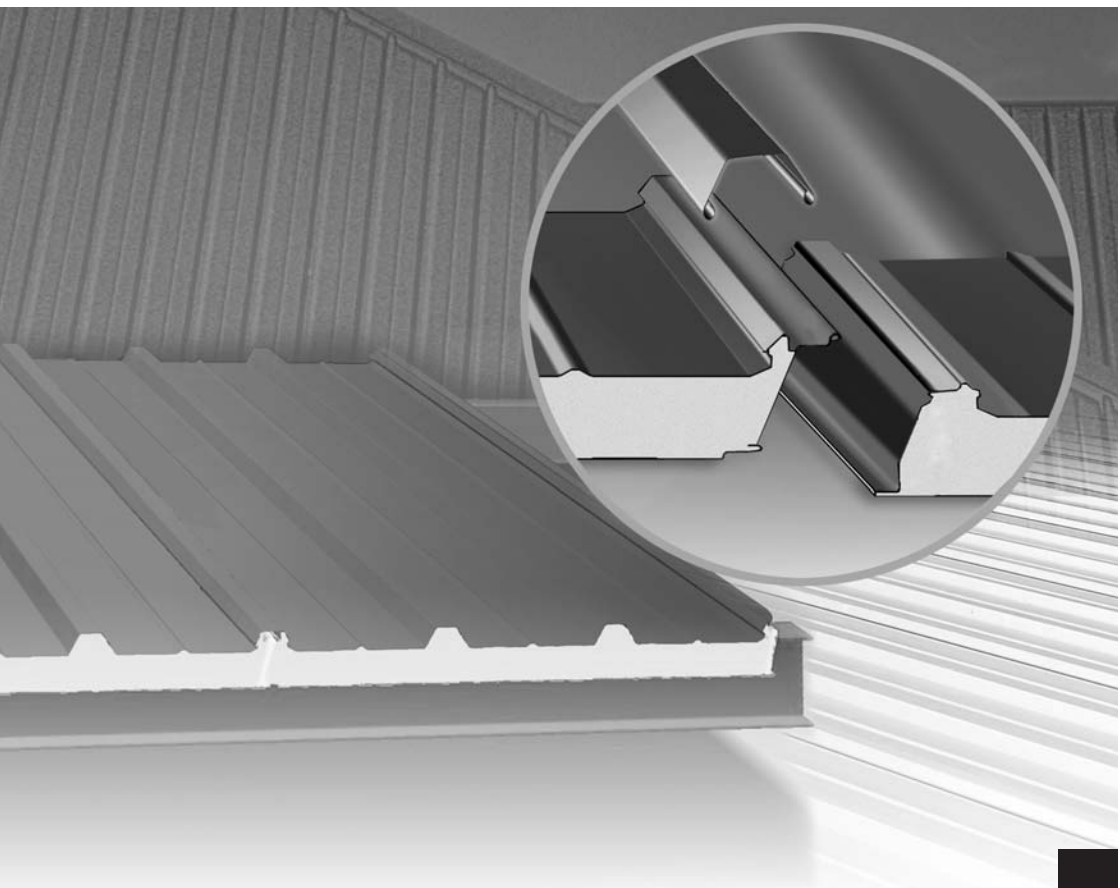

Index

	Page
1. Regulations / Guidelines	2
2. Unloading	3
3. Storage	4
4. Preparation for installation	4
5. Supporting widths	5
6. Protective foil (SF)	5
7. Cutting on site	6
8. Installation / Fastening	
8.1 General / Handling the panels	7-8
8.2 Aligning and checking	8-11
9. Panel cross joint	
9.1 Preparation	12
9.2 Notches provided by others	13
9.3 Cross joint sealing	14
10. Connections	14
11. Roof apertures / domelights	14-15
12. Other matters	15

Hoesch isodach integral®

Installation recommendations

You have decided in favour of a product from our Hoesch isodach® range, i.e. for a high-quality industrially fabricated product. Thank you very much! In order to ensure that after completion of the production process, the product will be treated with the same care as in our company, we would like to inform you about the following mandatory handling procedures:

1. Regulations / Guidelines

Among other things, the following must be noted:

- General official approval no. Z - 10.4 - 345 for sandwich panels issued by the building inspection authorities
- Technical information hoesch Hoesch isodach integral® (proposed designs).
- Accident prevention regulations issued by the Employers Liability Insurance Association
- Directive for the installation of profiled steel sheets for roofs, walls and ceilings issued by IFBS, Info 8.01
- Information for roofing using profiled steel sheets and strips, issued by Zentralverband des Deutschen Dachdecker-Handwerks
- Information on the structural analysis and on the laying plans relating to the project.

Installation recommendations

2. Unloading

Please check the hoesch Hoesch isodach integral® packages on their arrival on site. Any complaints and any evidence of damage must be recorded on the shipping documents and reported without delay to the appropriate ThyssenKrupp Bausysteme sales office

Complaints related to visible damage which are submitted later will not be considered.

Unloading and transport of the packages must be carried out singly, i.e. one at a time. Never unload two or more packages at the same time (pictures 1 + 3)! When using a fork lift truck for unloading, the two unloading aids supplied with the panels (dimensions 50 x 350 mm x panel width) should be arranged between the fork and the panels in such a way that the lowermost panel is protected from damage due to direct contact with the fork (picture 2). The unloading aid should be placed with its styropor side facing the package. The maximum package length is 8 m for this method of unloading; otherwise a fork extension with an additional fork arm must be used. When using a crane for unloading, a spreader bar as well as suitable, sufficiently dimensioned lifting slings (no ropes or chains) should be used. Make sure that the panel edges are well protected (picture 4). Fasten the slings to the spreader bar so that they hang vertically and can be pulled through in the area of the wooden pallet.

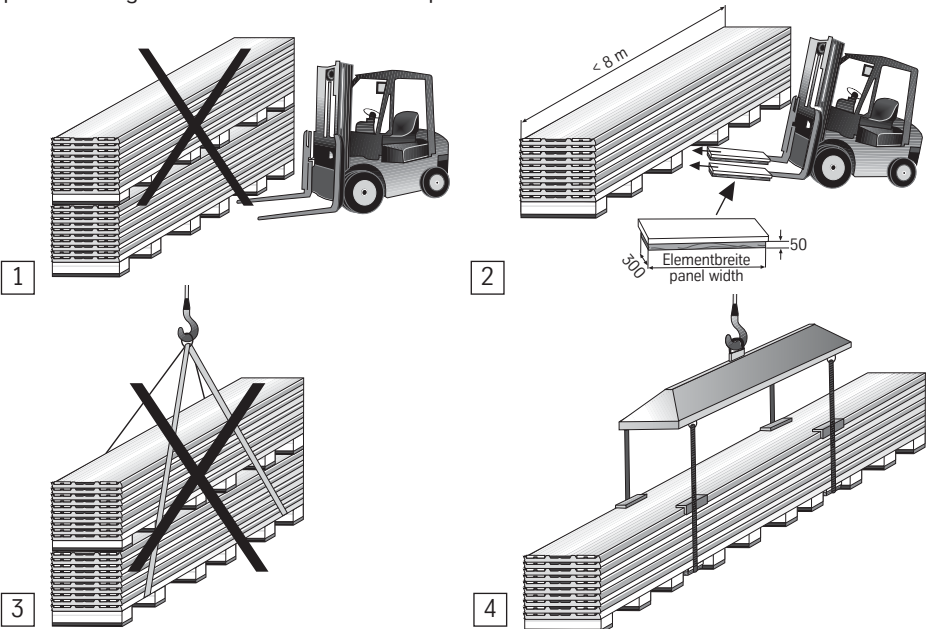

Installation recommendations

3. Storage on site

Store the Hoesch isodach integral® panels on a firm, dry and clean base. When the panels are stored outdoors, make sure that they are protected against rain, storms and dirt. The formation of condensate must be avoided. The panels should be stored in a slightly inclined position in order to allow any water that may have entered the package to drain out (picture 5). When Hoesch isodach integral® packages are stored for an extended period of time on site they should be protected by a textile cover and/or stored in a place where they are protected against direct weathering (e.g. under canopies or inside dry buildings).

For structural reasons, it is important that the packages are always stored above the trusses. Such intermediate storage must be co-ordinated with the works supervisor. Do not pile the packages one on top of the other (picture 7).

Do not store packages on Hoesch isodach integral panels® which have been installed already. Secure any packages which have been opened.

4. Preparation for installation work

Before commencing installation work, the supporting structure must be checked that it is suitable for the installation of Hoesch isodach integral® panels. Any defects must be reported to the works supervisor, in accordance with VOB.

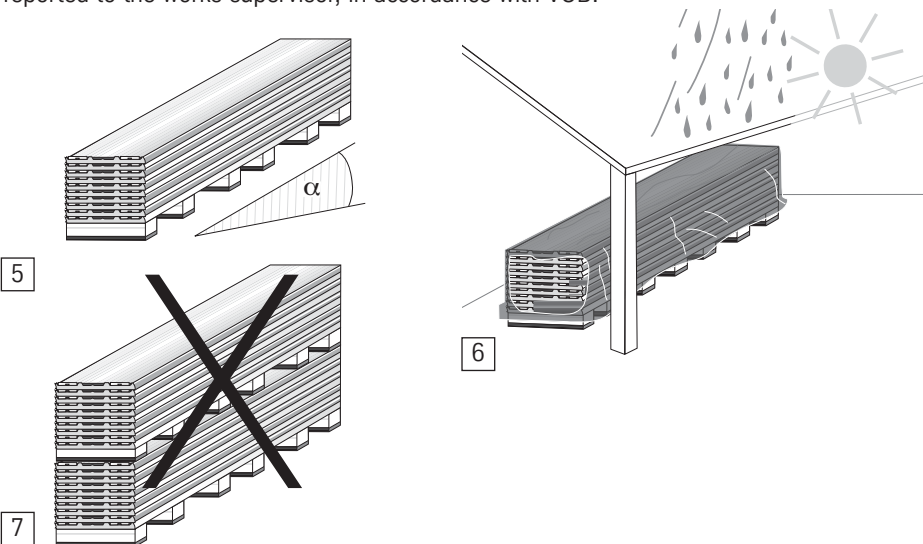

Installation recommendations

5. Supporting widths

The necessary supporting widths in the supporting structure are quoted in the structural analysis and in the laying plans relating to the project. The minimum supporting widths specified in the approval must be observed.

If no information is available, please refer to our table of supporting widths (www.tks-bau.com).

Minimum supporting width (picture 8):

Intermediate support	≥ 60 mm
End support	≥ 40 mm
Cross joint support	≥ 85 mm (see item 9)

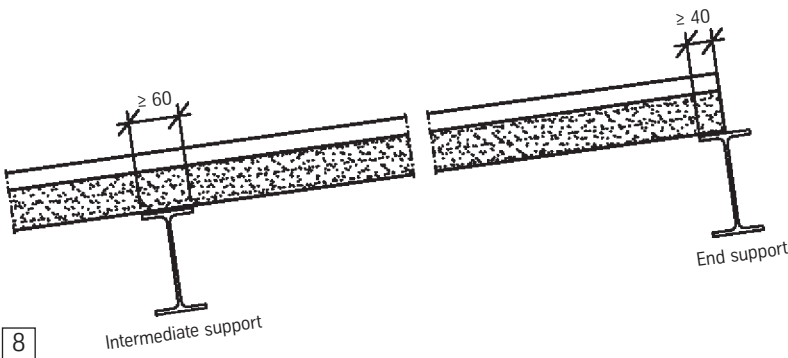

6. Protective foil (SF)

Hoesch isodach integral® panels are provided with a strippable foil to protect them from damage during transport and installation.

Please note!

The foil must be protected against UV radiation and must be pulled off during installation work but not later than six weeks after delivery of the panels to the site. In overlapping areas the protective foil must be removed before commencing installation work.

Installation recommendations

7. Cutting on site

Only use suitable cutting tools, e.g. a compass saw with fine teeth for the sandwich panels, plate shears and nibbler for other flashings (picture 9)..

Any chips must be removed immediately.

Thermal cutting processes (e.g. abrasive cutting machines) must not be used. The "Hoesch isotrim®" cutting tool has proved to be well suited for carrying out cuttings on site. It can be ordered from ThyssenKrupp Bausysteme (part no. Z00-011) (picture 10).

Any cut-outs in panels prepared before the panels are installed must be reinforced appropriately for transport on site.

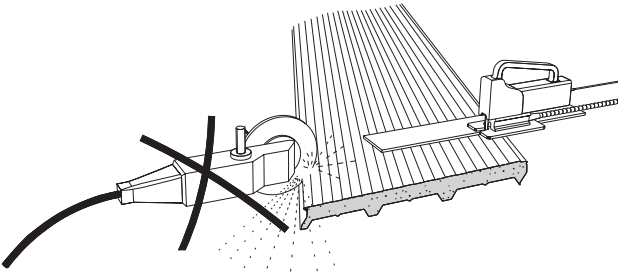

9



10

Installation recommendations

8. Installation / fastening

8.1 General / Handling the panels

Please note: Individuals are allowed to walk on the Hoesch isodach integral® panels for installation purposes only.

Short panels may be installed manually but for longer panels it is recommended that suitable aids are used (e.g. vertically holding using a screw clamp (picture 11). For very long elements a spreader bar should be used.

Fasten the panels to suit the roof slope (picture 12). The lifting devices must be secured so that they may not accidentally become undone (e.g. by slip-resistant rubber pads or by an additional sling).

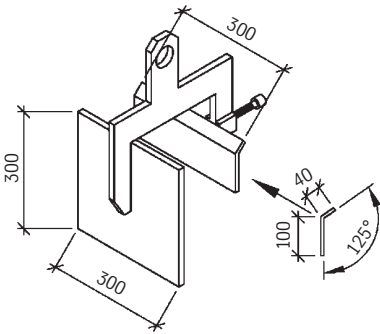

11

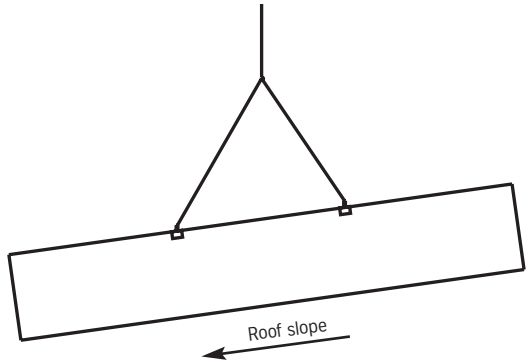

12

Installation recommendations

When removing single panels from a package, make sure that any distortion, bending and localised loads on the panels are avoided!

The panels should be transported vertically (picture 13 A+B)!

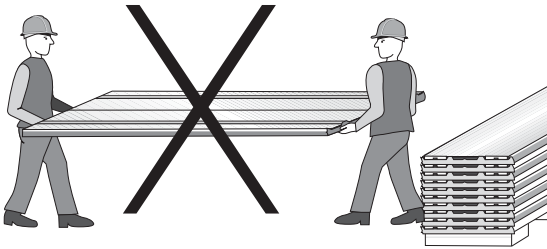

13 A

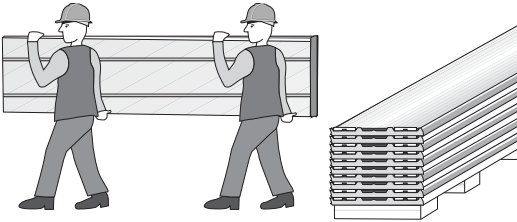

13 B

Secure any panels in packages that have already been opened so that they cannot slip.

8.2 Aligning and checking

The first panel must be exactly aligned and fastened.

It is not possible to correct the position of subsequent panels by realigning the longitudinal joint.

Install the following panels in such a way that the sealing tapes provided on the cover sheets are sufficiently covered and compressed (pictures 14 + 15).

Installation recommendations

The longitudinal joint is sealed by means of the sealing tapes, which are factory-applied, on the inside sheet and on the longitudinal overlap of the outside sheet. Tight sealing is only ensured when the correct cover width of 1000 mm and the specified fastening in the longitudinal joint are observed (picture 14). Fastening is always made using a panel holder (part no. Z33-051 or Z33-052).

For checking the cover width during installation, control marks spaced between 5 and 10 m should be provided on the supporting structure.

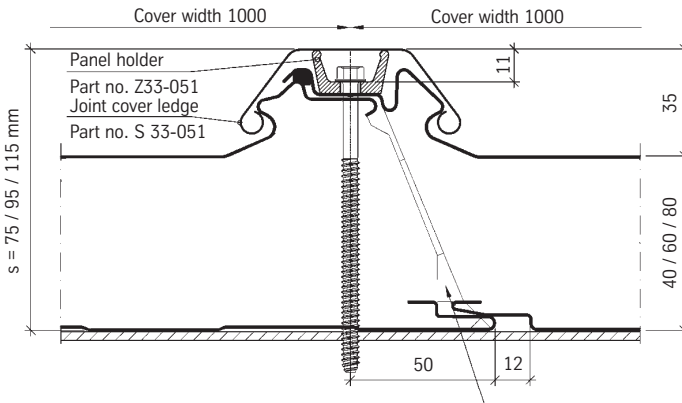

14

Close joint gap in the eaves area using sealing tape 10 x 30 mm, Part no. Z70-A03

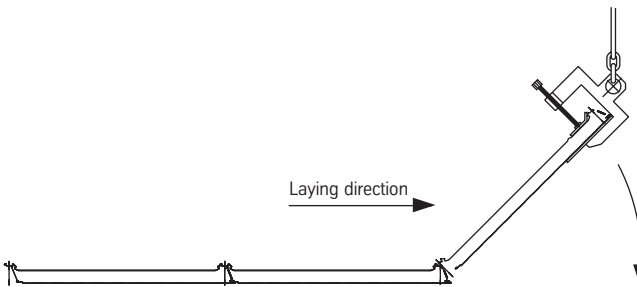

15

Installation recommendations

For fastening the roof panels, only use officially approved stainless steel fasteners. No washer is required below the screw head (see pict. 14).

Hoesch isodach mono® panels are fastened to the purlins at the crossing point of the longitudinal joint and the purlin.

Where visible fastening is required for structural reasons, e.g. in the area of the roof edge, it is recommended that so-called 'façade bolts' (with supporting thread under the head) and washers, both made of stainless steel, are used. For the number of bolts, their size and their spacing, please see the structural analysis and the installation plan, respectively.

The panels may be fastened to steel supporting structures, concrete supporting structures (using a HTU rail), bonded trusses or other timber structures. When fastening to timber, the holes must be predrilled as specified by the manufacturer of the fasteners. Close the end of the joint gap (eaves side) by inserting sealing tape 10 x 30 in a cross-wise direction (pictures 14).

Where high demands are imposed on the tightness of the longitudinal joint, or in the case of high deflections and loads approaching the load-bearing capacity, it is recommended that screws are also provided in the longitudinal joint between the points of support (picture 16).

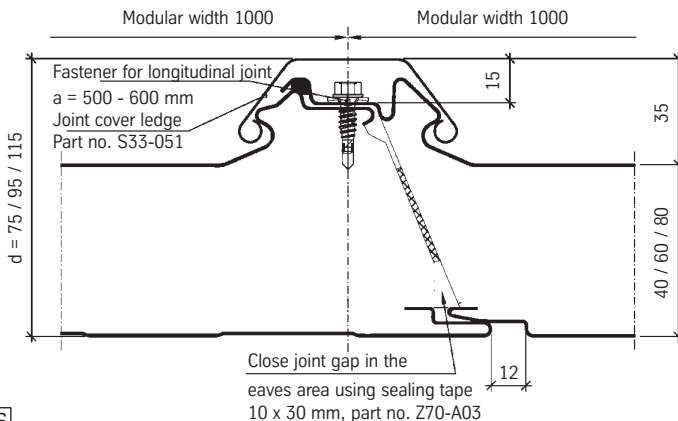

16

Installation recommendations

Connect the longitudinal joints after the panels have been fastened to the supports (e.g. purlins).

Only use officially approved fasteners with an unthreaded portion under the head, with a minimum length of 16 mm, with washers, both made of stainless steel. The spacing between fasteners should be a maximum of 600 mm.

Provide the longitudinal joint with a joint cover ledge (part no.: S33-051), see picture 17. When the cover ledge is made up of several pieces to cater for the roof length, take care that joints between the pieces are not located above a cross joint between roof panels or in curb connecting areas. Slide the top joint cover ledge into the base ledge (1) and clip it on (2).

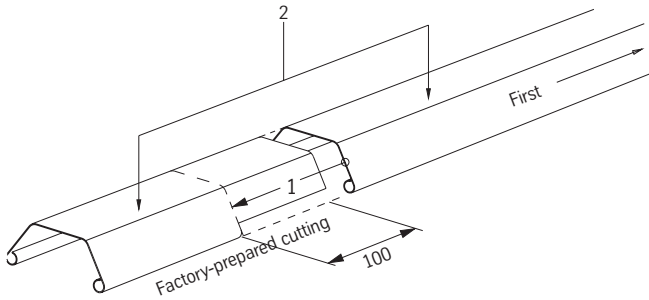

17

Installation recommendations

9. Panel cross joint

9.1 Preparation

Hoesch isodach integral® panels can be produced with a max. length of 24 m. However where roof slopes are longer than this or for reasons of transport, a cross joint may be necessary. In this case, the roof slope should be at least 5°.

Depending on the direction and sequence of installation (pictures 18 + 19), panels A + D (eaves panels) and B + C (ridge panels) must be differentiated. Panels B and C can be ordered with a foam-free zone (eaves side).

When foam is removed on site, proceed carefully to ensure that the foam-free area is absolutely clean (foam residues and foreign matter may cause leakage) and that the corrosion protection on the surface is not damaged.

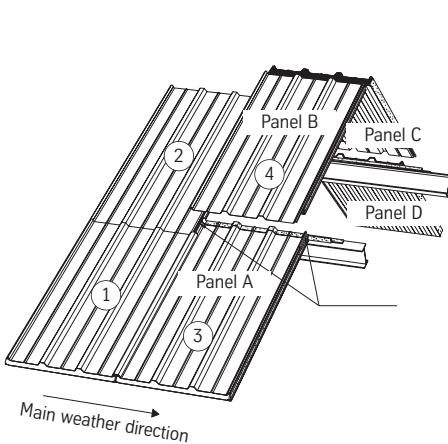

18

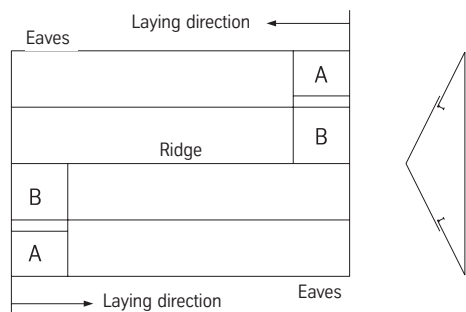
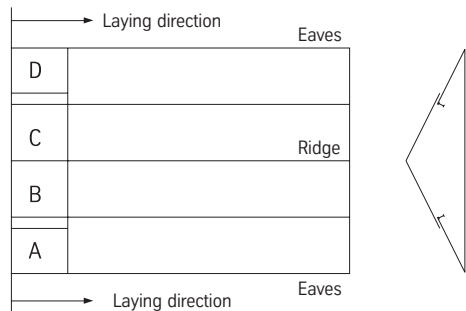

19

Installation recommendations

9.2 Notches provided by others

While panels B and C (ridge panels) are ready for installation, provided that they have a foam-free area, panels A and D (eaves panels) must be notched before they are connected at the cross joint. Notching is to be carried out by others as shown below (picture 21).

For forming the cross joints, the following procedure is recommended: first lay and fasten panels A and D, then panels B and C.

Panels B and C overlap panels A and D by 200 mm (pictures 20 + 22).

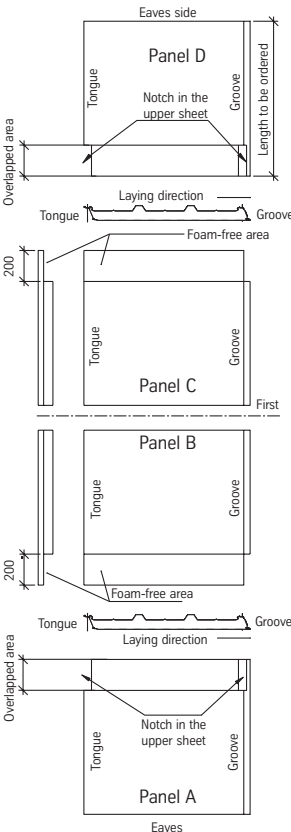

20

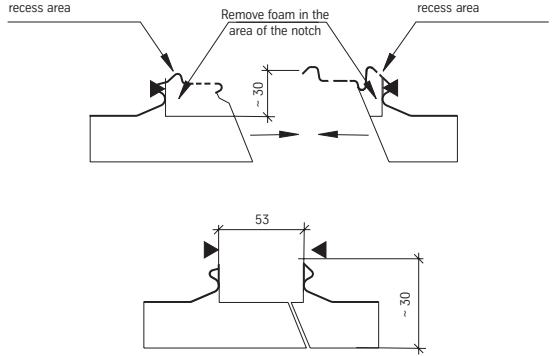

▼ Flatten the sides using flat nose pliers

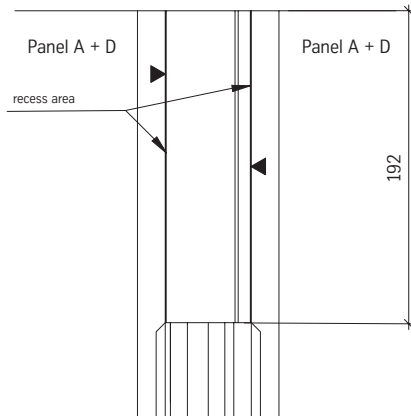

21

Installation recommendations

9.3 Cross joint sealing

Proceed carefully when sealing the cross joint (picture 22). Special attention must be paid to ensuring a vapour-tight connection with the inside sheet.

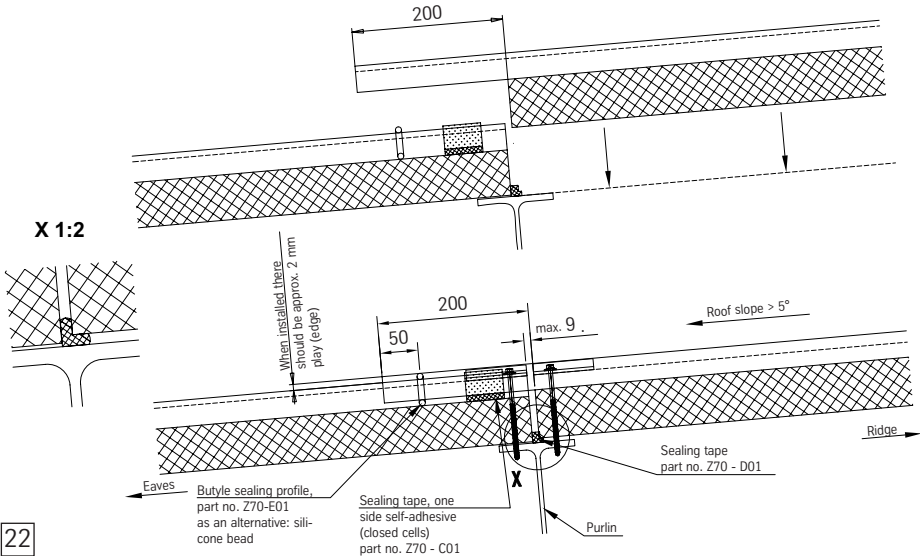

10. Connections

For a number of types of connection, e.g. for barge boards, eaves, ridges etc., recommended solutions can be downloaded from our website (www.tks-bau.com).

11. Roof apertures / dome lights

Roof apertures must be provided to comply with structural requirements, and the roof must have a minimum slope of 5°. It is important to ensure that the water-carrying outside sheet is tightly fitted, and that water is drained effectively so as to prevent clogging of beads which would lead to standing water on the roof. Furthermore, the vapour-sealing effect of the inside sheet must be maintained. Connections to roof apertures require careful sealing.

Installation recommendations

Dome lights, smoke and heat extraction systems, roof hatches etc. are built in during roof installation using special curbs which are adapted to Hoesch isodach integral®, preferably thermally insulated sections.

The colour of curbs may be selected to suit the coating of Hoesch isodach integral®. Slight variations in colour and degree of gloss are possible due to the coating systems and the methods of application.

Thermally insulated curbs are installed as described in chapter 9 'Panel cross joint'.

12. Miscellaneous

These installation recommendations are based on many years of experience by us and our customers. They have been prepared to the best of our knowledge. The latest version of our technical documents, and also these recommendations for installation can be found on our website www.tks-bau.com

If the above procedures are not observed, any right to make a complaint in the event of damage will be inadmissible.

Observance of the recommendations does not release the user of our product from his obligations of complying with the local situation and circumstances.

Final remark:

Hoesch isodach integral® is a high-quality roofing system and must not be used as an installation platform either for ones own work or for work of other trades.

The accident prevention regulations must be observed.

ThyssenKrupp Bausysteme GmbH

Hammerstrasse 11

D-57223 Kreuztal

Phone + 49 / 27 32 / 599 1 221

Fax + 49 / 27 32 / 599 1 219

E-Mail: export.tks-bau@thyssenkrupp.com

Internet: www.tks-bau.com



Die einzelnen Angaben in dieser Druckschrift gelten nur dann als zugesicherte Eigenschaft, soweit sie jeweils im Einzelfall ausdrücklich als solche schriftlich bestätigt sind. Technische Änderungen vorbehalten.
GB • Info 2.4.4 • 7.2007 • bc